



# VULCAN II    VULCAN II Air

PUNCHING TOOLS GUIDE



We pursue processing and production technologies and support our customers' production by providing high-quality products.



**MURATA TOOL, Ltd. supports your manufacturing with our dedication to quality.**

Since established in 1990 as an official tooling maker of Muratec turret punch press and press break machines, MTL has been evolving for a stable supply of high quality products. Along with tooling production, MTL also develops its own fabrication machines, like deburring machine, key sheater, cold hydraulic riveter.



## Tool Selection Guide

Tool Selection	4
Available Size Chart	4
Tool angles	5
Tool compatibility	6
Coating	6
Ejector	7
Corner R die	7
Punch holder dimensions	8
Die holder/die adapter	8
Tool replacement method	
X,A,B,C,D,I/FB,I/FC,I/D range	9
Tool replacement method	
E,F,G,H,J,I/F range	10
Precautions before Use	11
Special tool shapes	12
Punching tonnage	13
Regrinding Punch and Die	13
Punch/Stripper Size	14
Die Size and Shape	15
Shim (Die)	16
Recommendation die clearance	16
Minimum die clearance	16

## Standard Tool

X	range	17
A,B,I/FB	range	17
C,I/FC	range	18
D,I/FD	range	18
E	range	19
F,I/F	range	19
G	range	20
H	range	20
J	range	21

## Special Tool

Multi tool	22
Work Holder Safety Tool	22
Seamless Tool ST-IV	23
Smart Slitting Tool	23
Fine Nibbling Tool	24
SHO-KEI Punching Set	25
↑ Punch assembly procedure	26

## Forming Tool

Marking Tool	27
FP Punch holder	28
Burring	29~31
High speed marking	31
Center punch(top marking)	32
Center punch(bottom marking)	32
Locater Point	33
Positioning	33
Coined Countersink	34~35
Emboss	36
Countersink	36
Knockout	37
Engraved/logo mark	37
Bridge	38
Lance	38
Bead	39
Louver	40
Forming Tool UP/DOWN	41
Forming Tool UP/DOWN	
Tool Change Procedure	42
Ball Tool (BT-III)	43
Laser Edge Tool (BL- I )	44
Style 114 Punch Holder	45

# Tool Selection

1) As a thin punch breaks easily, the minimum diameter (width) is limited according to materials and thickness.

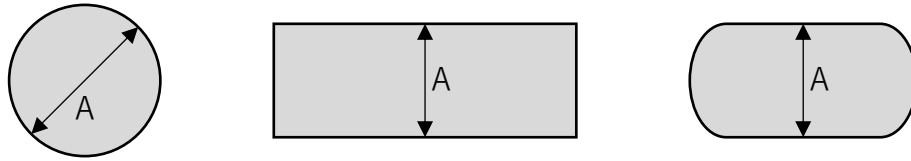

Mild steel, Aluminum :  $A \geq t$  (Sheet thickness size or more)

Stainless :  $A \geq t \times 2$  (Twice as large as sheet thickness or more)

2) For continuous overlapping punching, its pitch must be half of tool length or more.

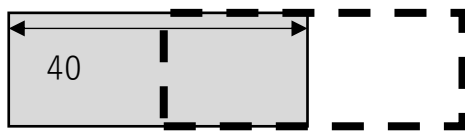

Example: Pitch 20 or higher  
Pitch  $\geq$  Tool length x 0.5

3) Do not conduct continuous overlapping punching in the direction of the width. The dies may cause galling.

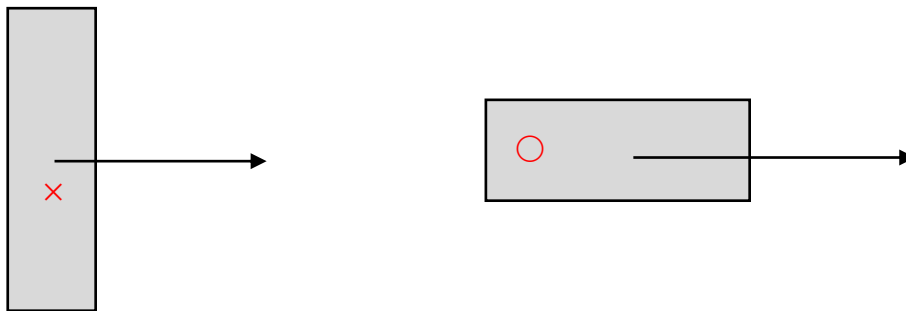

## Available Size Chart

Range	Pressure resistance [ton]	Mild steel			SUS		
		t 3.2	t 4.5	t 6.3	t 2	t 2.5	t 3
X	6	39.9	37.7	28.3	39.8	39.9	37.7
AB	12	78.5	75.4	56.6	78.5	78.5	75.4
C	17	119.4	108.4	80.1	119.4	119.4	106.7
D	25	157	157	119.4	157	157	157
EF	30	235.6	190	142.9	235.6	226.1	188.4
GHJ	30	266.9	190	142.9	282.6	226.1	188.4
Index	15	133.5	94.2	70.7	141.3	113.1	94.2

The values in the above table are punch circumferences.

# Tool Angles

- The below defines the angles of the shape when the processed work is seen from the top.
- A rectangle at 0 degree refers to the one laying horizontally.
- For additional angle(s), visual information is preferred to prevent from being occurred mutual misunderstanding.

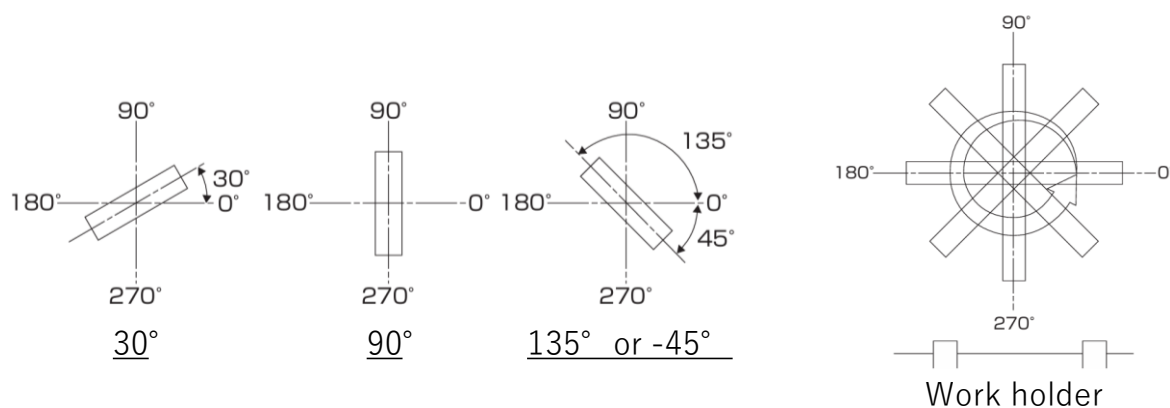

Angles available with MURATA items

	0°	45°	90°	135°	180°	225°	270°	315°
Punch Holder	○							
Die Holder(B~D)	○		○	○	○	○	○	
Die Holder(E~)	○	○	○		○		○	○
Punch	○		○					
Die (Multi other than)	○							
Multi Punch、 Die	○							
Stripper (B~F)	○	○	○	○	○	○	○	○
Stripper (G,H,J)	○		○		○		○	

※Subject to the above table

- Punch Holder : All Wiedemann Tools
- Die Holder : Slide in Die Holder
- Punch、 Stripper : Vulcan、 Vulcan II、 Vulcan II Air

# Tool compatibility

	Range													
	X	A	B	I/FB	C	I/FC	D	I/D	E	F	I/F	G	H	J
Punch Holder										○				○
Punch			○		○		○			○				○
Stripper			○		○		○				○			
Die			○		○		○				○			

- ※ • Subject to the above table : Vulcan II 、 Vulcan II Air
- The C to J range comes in two types: round and irregular.
- The stripper is not compatible with Vulcan II and Vulcan II Air.

# Coating

Coating extends the life of the punch.  
It improves impact resistance, abrasion resistance, and chipping resistance, and also helps prevent edge build-up (seizure).

Types	Applicable materials	Lifespan	Features
Ultra hard processing (UHP)	Stainless Aluminum	About 1.3 times	Low cost and no drawback of the coating peeling off
Ultra guard processing (UGP)	Mild steel Stainless	About 3 times	Tougher surface than UHP - longer life, preventing build-up edge
TICN coating	Mild steel • Stainless Aluminum	About 6 times	Titanium carbide film is formed on titanium nitride film Longest life

Additional charges will apply.

# Ejector

There are four types of ejectors.

The ejector dimensions vary depending on the punch dimensions.

Not applicable for sizes less than  $\Phi 6$  or widths less than 6.

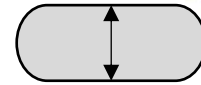
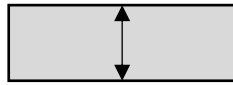
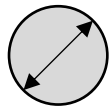

## Punch dimensions

$6 \leq \Phi < 10$ $6 \leq \text{Width} < 10$	$10 \leq \Phi < 20$ $10 \leq \text{Width} < 20$	$20 \leq \Phi < 38$ $20 \leq \text{Width} < 38$	$\Phi 38 \leq$ $\text{Width} 38 \leq$

※For round shapes, the following ranges apply: X-D range, E, F ranges less than  $\Phi 30$ , and G, H, J ranges less than  $\Phi 40$ .

Square shape

Punch dimensions	Ejector diameter	Quantity
$25 \leq \square < 40$	$\Phi 4$	4
$\square 40 \leq$	$\Phi 6$	4

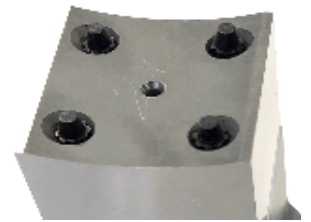

Round shape (E to J range)

Punch dimensions	Ejector diameter	Quantity
$\Phi 30 \leq$ (E, F range)	$\Phi 4$	4
$\Phi 40 \leq$ (G, H, J range)	$\Phi 4$	4

# Corner R die

By adding R to the corners of square and rectangular dies according to the clearance, the die clearance becomes uniform around the entire circumference.

It can reduce corner burrs.

You can continue to use the punch by simply changing the die.

When placing an order, please write the details in the comments section and we will create the mold for you.

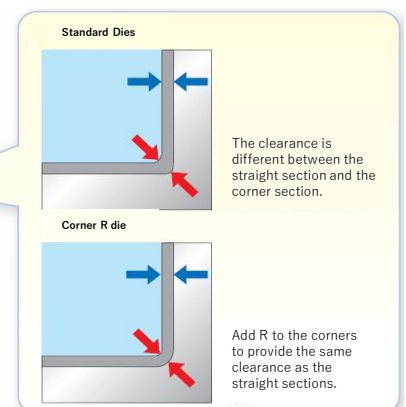

※

When processed with a die with an R, the corners on the back of the product will have an R.

As the die clearance increases, the R size also increases.



# Punch holder dimensions

## Adjustment of Punch Height

With the Vulcan II punch holder, the punch height after grinding can be adjusted without using shims.

The smallest adjustable quantity is 0.38mm. Therefore, the punch height changes slightly depending on the amount of grinding.

X,B,C,D range  
Index FB,FC,D,FD range

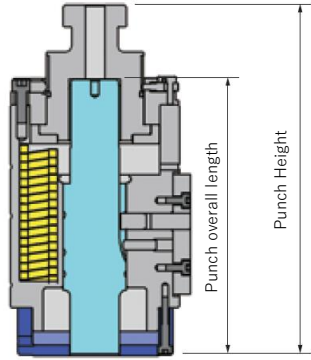

EF,GHJ range  
Index F range

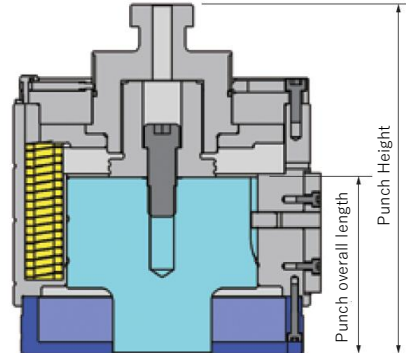

Range	X	B	I/FB	C	I/FC	D	I/FD	I/D	E	F	I/F	G	H	J
Punch overall length	145			139			89							
Punch Height	174.3~174.7						176.7~177.1							

## How to register machine tool

Use "Vulcan" for registering a tool type of the machine.

When registering an air blow mold, please check "Air blow" in "Processing conditions".

However, since the load of the punch holder spring differs from that of the Vulcan Tool, remove the stripper when using "Tool alignment".

# Die holder/die adapter

## Die holder

(B/B range)



(X/C,X/D range)



(E,F range)



(G,H,J range)



## Die adapter

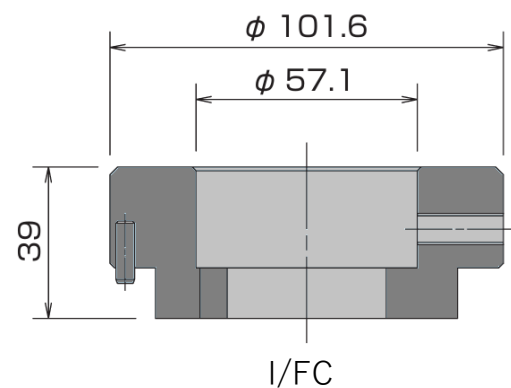
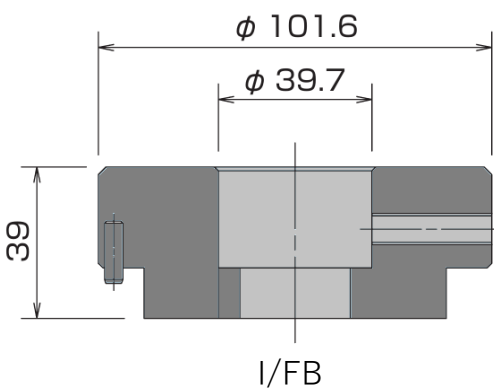

# Tool replacement method X,A,B,C,D,I/FB,I/FC,I/D range

Below is the mold exchange for the "X, A, B, C, D, I/FB, I/FC, I/D range" of Vulcan II and Vulcan II Air.

1、 Unlock the rotation of the tang.

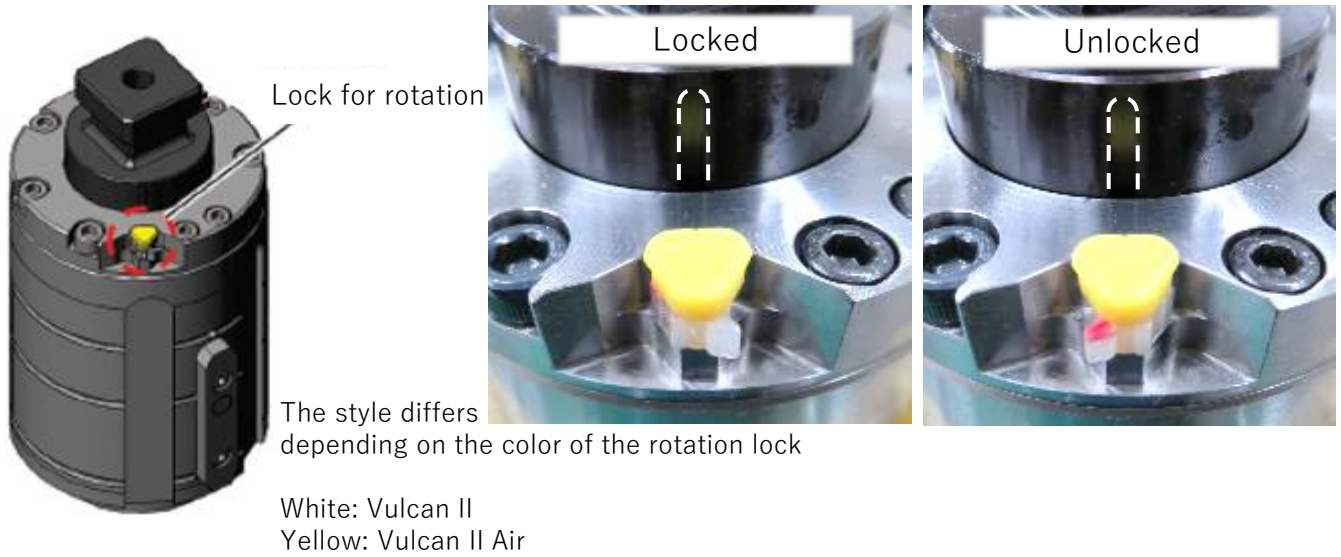

2、 Adjust punch height by inserting a punch into the punch holder and rotating the tang. When rotating the tang, do not use tools. Turn it by hand.

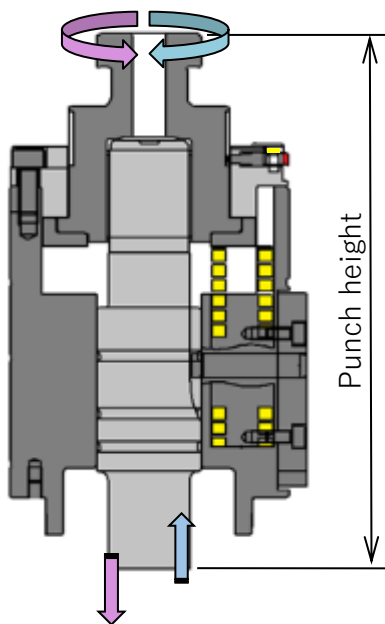

You can adjust 0.38mm of punch height by turning the tongue 1/4 turns.

Range	Punch height
X A B C I/FB I/FC	174.3~174.7
D I/FD I/D	176.7~177.1

When adjusting the Punch height, stop with the "tang vertical groove" on the extension of the "rotation lock" and measure.

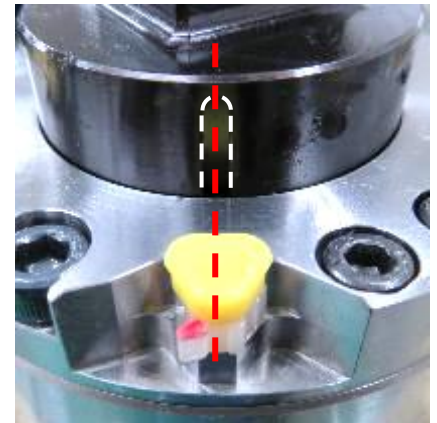

3、 Lock the tongue rotation lock and attach the stripper.

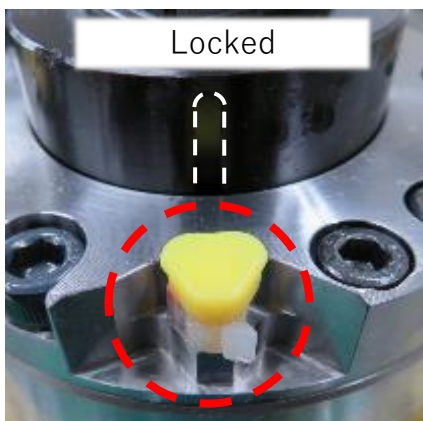

※ Make sure the rotation lock is in the locked position before inserting it into the turret. If the punch holder is set in the turret while it is in the unlocked state, the punch holder tongue will collide with the ram when the turret rotates, causing the machine to malfunction.

To remove the punch for grinding, etc., remove the punch in the reverse order of steps 1 to 3.

# Tool replacement method E,F,G,H,J,I/F range

Below is the mold exchange for the " E,F,G,H,J,I/F range" of Vulcan II and Vulcan II Air.

## 1、Unlock the rotation of the tang.

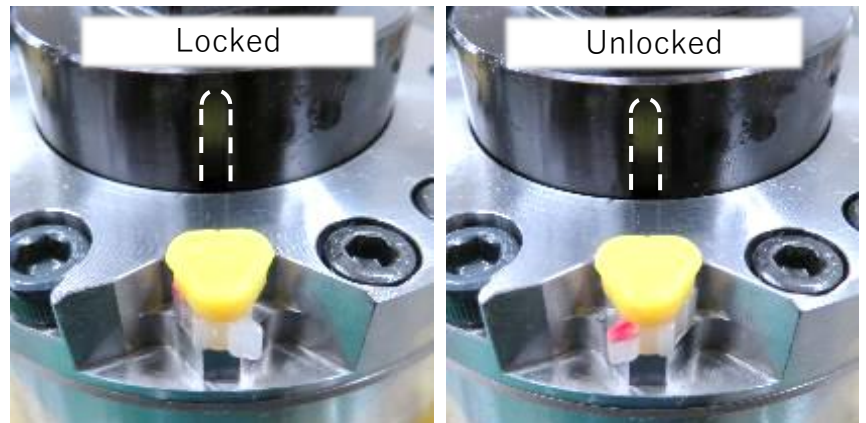
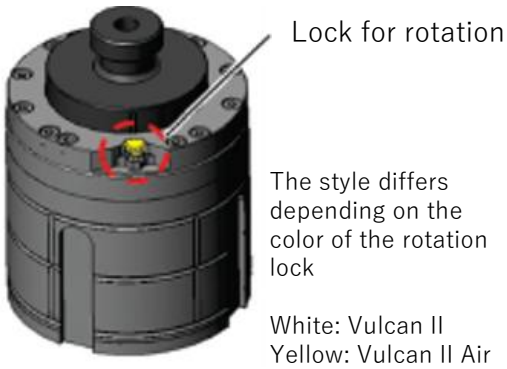

## 2、Insert the punch into the punch holder and tighten the lifting bolt to fasten the punch.

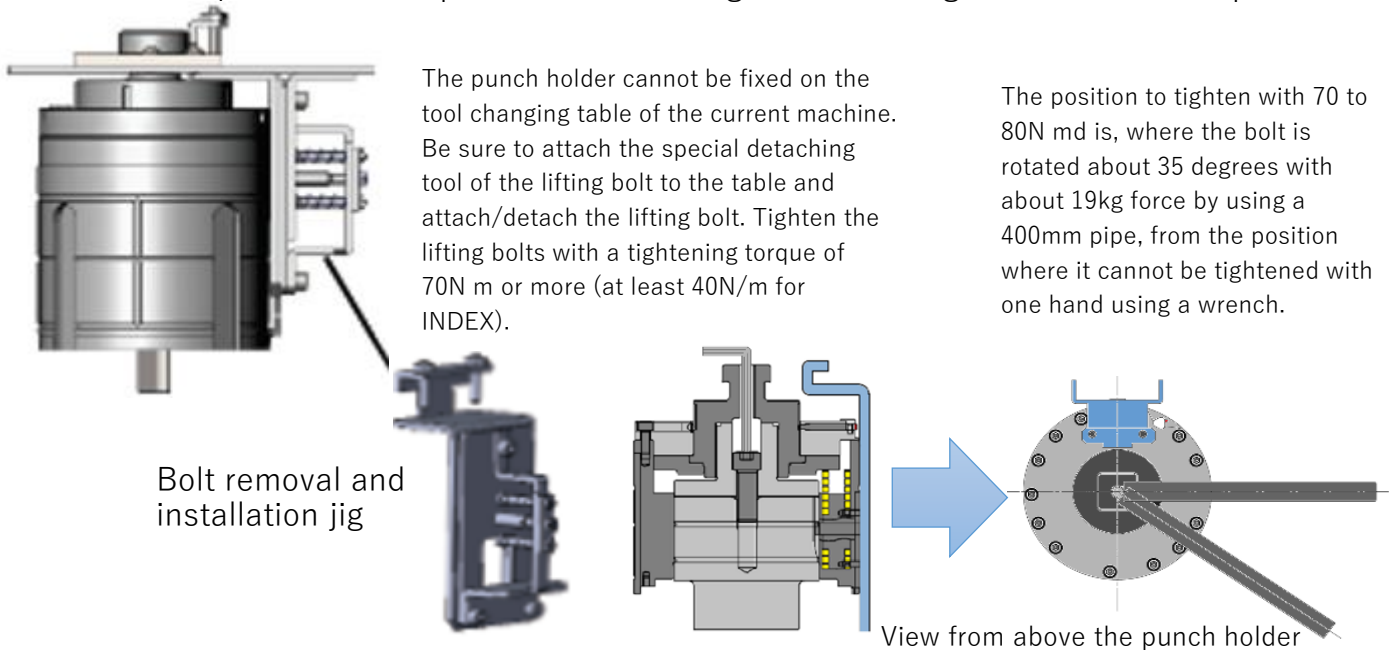

## 3、Adjust the punch height by rotating the tang.

When rotating the tang, do not use tools, turn it by hand.

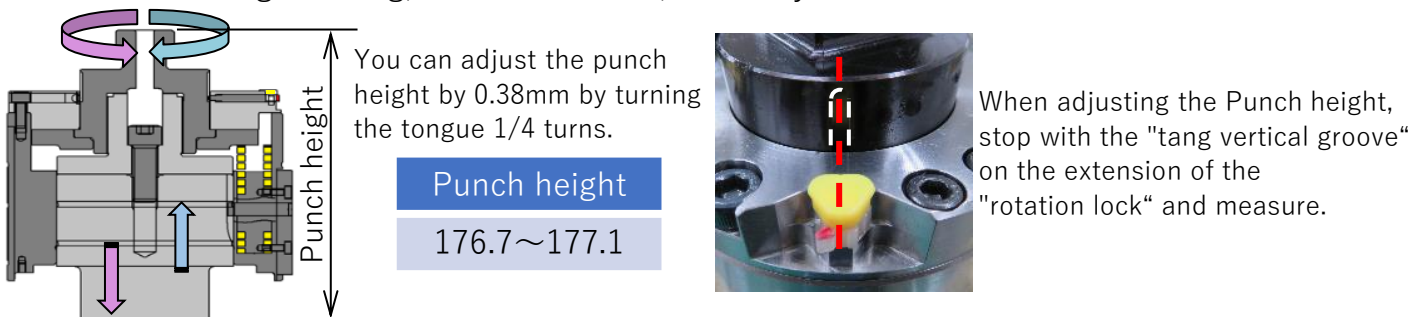

## 4、Lock the tongue rotation lock and attach the stripper.

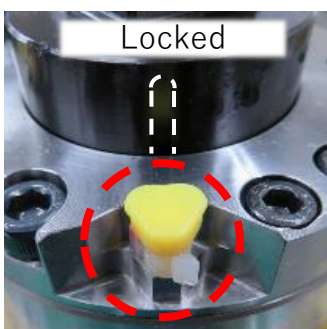

※ Make sure the rotation lock is in the locked position before inserting it into the turret.  
If the punch holder is set in the turret while it is in the unlocked state, the punch holder tongue will collide with the ram when the turret rotates, causing the machine to malfunction.



Punch remove tool

To remove the punch for grinding, etc., remove the punch in the reverse order of steps 1 to 3.

# Precautions before Use

## Prevents burn-in

Clean the upper turret by passing the key groove from the top to the bottom to prevent the key from seizing.

The sliding parts of the punch and punch holder require regular application of lubricant or grease.  
Recommended : Moly Oil Spray F100  
Air Blow Oil

The Vulcan II Air cannot be greased, only oil.  
(Vulcan II Air also requires initial oil application.)

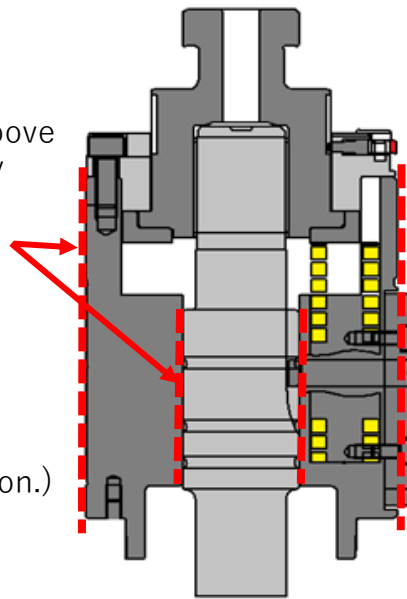

## Damage prevention







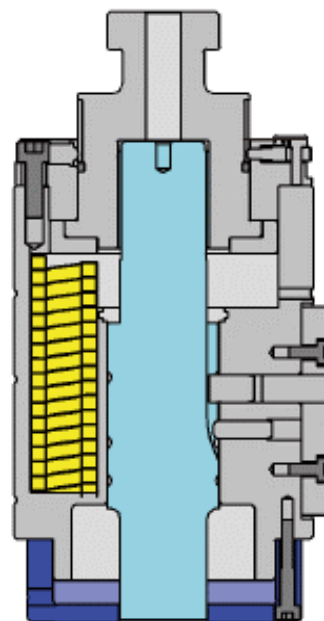



Never disassemble the punch holder.

If disassembled, parts may scatter, causing injury or damage to the surrounding area.



# Special tool shapes

Classification	Shape					
Standard						
Standard	Round	Square	Rectangle	Oblong	SD	WD
Special shapes (S1)						
Special shapes (S2)						
Special shapes (S3)						

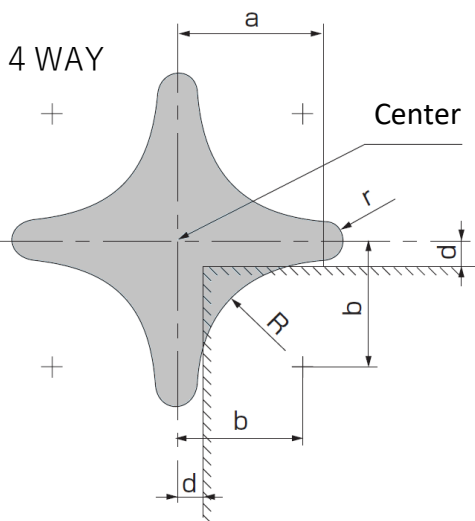

Range	R	a	b	r	d
B	2	6	4	1.59	2
	3	7	5	1.58	2
	4	8	6	1.56	2
	5	9	7.5	2.13	2.5
	6	10	8	1.53	2
C	8	12	10	1.5	2
	10	14.5	12.5	1.96	2.5
	13	17	15	1.43	2

HEXAGON

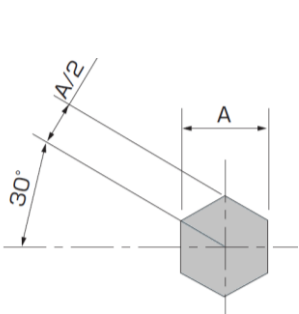

OCTAGON

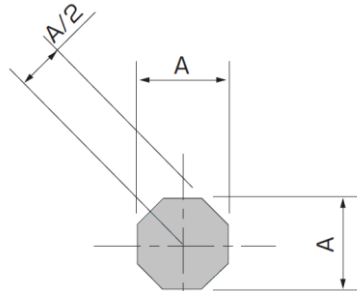

CONER RADIUS

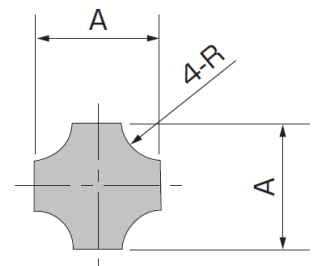

ELLIPSE

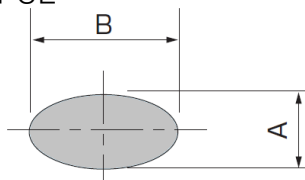

TRAPEZOID

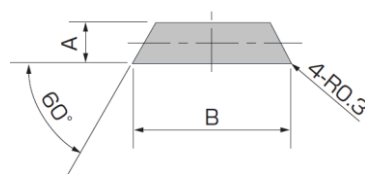

DAIAMOND JOINT

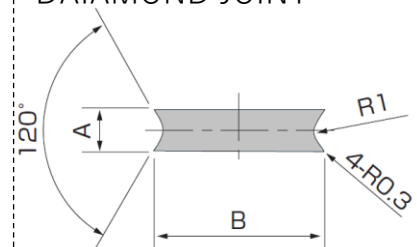

# Punching tonnage

Tonnage of punching is determined by the perimeter of the shape to cut, as well as the thickness and the shearing resistance of the object to be processed. Shear angles help tonnage reduces.

## WITHOUT SHEAR ON PUNCH

$$P = A \times \tau \times t \div 1000$$

P : Tonnage (kN)

t : thickness (mm)

A : perimeter

K : shear coefficient

## WITH SHEAR ON PUNCH

$$P = A \times \tau \times t \times K \div 1000$$

$\tau$  : shearing resistance (N/mm<sup>2</sup>)

- shearing resistance  $\tau$  (N/mm<sup>2</sup>)  
mild steel : 260~350    Aluminum : 150~220    Stainless : 520~560
- shear coefficient K

thickness	1.2	1.6	2.0	2.3	3.0	3.2	4.0	5	6.3
shear coefficient	0.5	0.5	0.5	0.5	0.61	0.63	0.71	0.75	0.83

- Tool shape and shear angles

range	Shape and size		shear angle
X,B,C	Round/irregular shape		No shear
Multi tool			
D $\leq$	Equivalent to C range size Diagonal length 30 or less		Roof top shear Concave shear
	Round/Rectangle/oblong	Width < 15	
		15 $\leq$ Width	
Round ( $\phi$ 38 <)			

※If you wish, we can also attach shear angles below C range.

# Regrinding Punch and Die

Shape	Size	thickness (mm)					
		1.0	1.6	2.3	3.2	4.5	6.0
Round	D $\leq$ $\phi$ 1.5	1.5	1.0	-	-	-	-
	$\phi$ 1.5 < D $\leq$ $\phi$ 4	4.0	3.5	2.5	2.0	-	-
	$\phi$ 4 < D	5.0	5.0	5.0	5.0	4.0	3.0
Round Rectangle Oblong SD/WD	Width $\leq$ 2	1.5	1.0	-	-	-	-
	2 < Width $\leq$ 4	5.0	4.5	3.5	3.0	-	-
	4 < Width	5.0	5.0	5.0	5.0	4.0	3.0

- Maximum grinding is 3mm for SUS material and thickness 2.5mm or more.
- Other than the above, the grinding amount varies depending on tool shape. Contact Murata Tool for more information.
- When grinding more than 3mm, additional machining of the ejector hole is required.
- When punching a sheet whose thicknesses exceeds 6mm, the maximum grinding is 2.5mm.
- Even if the maximum grinding amount is 3mm or more in the above table, if the punching tonnage exceeds the value below, the maximum grinding amount is 3mm.

range	X	B	C	D	E,F	G,H,J	INDEX
Tonnage	5.0	10.0	15.0	23.0	No constraint		

# Punch/Stripper Size

## Punch dimensions

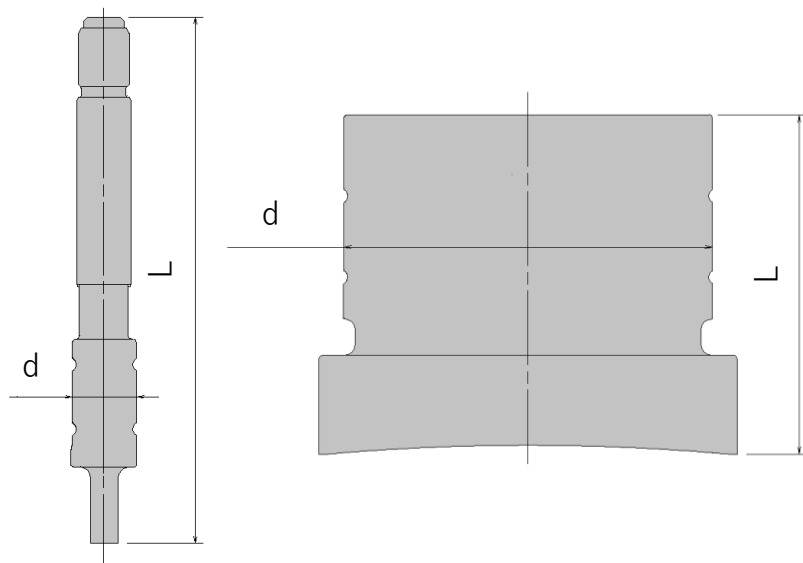

Range	$\Phi d$	L
X	18	145
A,B,I/FB	26	145
C,I/FC	26	139
D,I/D,I/FD	32	139
E,F,I/F	55	89
G,H,J	97	89

### Metal Stripper



Range	$\Phi d$	L
X	41	22.1
A,B,I/FB	49.5	22.1
C,I/FC	69.8	22.1
D,I/D,I/FD	78	24.5
E,F,I/F	98.6	29.4
G,H,J	143.2	29.4

### Urethane Stripper (Vulcan II Air cannot be used)

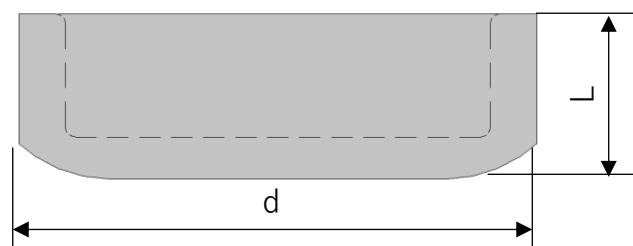

Range	$\Phi d$	L
X	36	22.1
A,B,I/FB	48	22.1
C,I/FC	70	22.1
D,I/D,I/FD	76.5	24.5
E,F	106.5	24.5
G,H,J	24.5	24.5
I/F	97	15.8

- This is a simplified diagram.  
There are some parts that may differ slightly from the actual shape.
- When using a urethane stripper of E station or higher, a dedicated adapter is required.
- There are guide strippers available as metal strippers with an extremely small gap between the punch and the stripper.  
Vulcan II:  $\Phi 6$ , width 6 or less    Vulcan II Air:  $\Phi 3$ , width 3 or less  
If you use a guide stripper other than the above, an additional fee will be charged.  
Round, square, Rectangle, oblong, SD and WD are all possible.

# Die Size and Shape

## Die dimensions

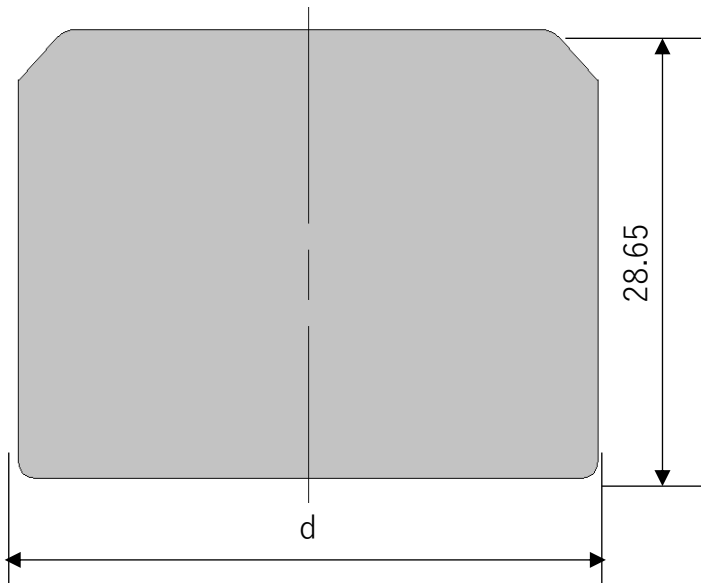

Range	$\Phi d$
X,A	39.7
B	39.7
C	57.1
D,I/D,	69.8
E	88.9
F,I/F	101.6
G	114.3
H	133.3
J	152.4

## Die cutting blade type

Type	Features	Slug Pulling	Price
Standard	Round/Irregular/Standard	○	Standard
All Taper1°	Effective for anodized aluminum	○	Standard
SW (Slug wiper)	Prevent slug pulling efficiently	◎	Standard × 1.3
Large cutting edge	Regrinding allowance is up to 2 mm	△	Standard

The grinding allowance for all cutting edges other than the large cutting edge is 1 mm.

# Shim (Die)

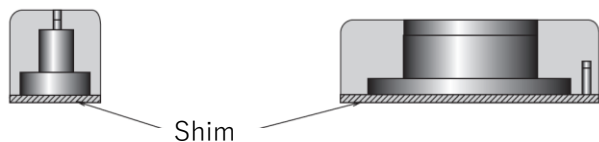

Shim

## Die shim Price

Shim Thickness	Range							
	X,A,B	C	D	E	F	G	H	J
t0.3	450	510	650	790	850	1,100	1,260	1,560
t0.5	530	630	720	920	990	1,160	1,360	1,860
t1.0	600	830	880	1,220	1,360	1,500	1,620	2,660

## Recommendation die clearance

Recommendation die clearance	Thickness (mm) Servo Type			Thickness (mm) Mechanically driven		
	Mild steel	Stainless	Aluminum	Mild steel	Stainless	Aluminum
0.2	~1	~0.8	~1.2	~1.2	~0.8	~1.2
0.25	1.2	1~1.2	1.5	1.6	1~1.2	1.5
0.35	1.6	1.5	2	2.3	1.5	2
0.4	-	-	-	-	2	-
0.5	2.3	2	3	3.2	3	3
0.6	-	-	-	-	-	4
0.7	3.2	3	4	-	-	-
0.75	-	-	-	4.5	4	5
0.9	4.5	4	5	-	-	-
1.0	-	-	-	6	-	-
1.2	6	-	6	-	-	-
To thickness	20~25%	25~30%	20~25%	15~20%	20~25%	15~20%

## Minimum die clearance

- Please note that the minimum clearance varies depending on the cutting edge shape.
- Refer to the table below to prevent galling of the punch and die.
- If the plate thickness is 0.5 mm or less, the minimum clearance is larger than the recommended clearance, resulting in larger burrs.

Round/Rectangle/Oblong/SD/WD			Special other than those listed on the left		
Standard	Multi tool	Index	Standard	Multi tool	Group Type
0.12	0.2(Round0.15)	0.2(Round0.15)	0.15	0.2	0.2(Round0.15)

# X range

Round only  
~12.7

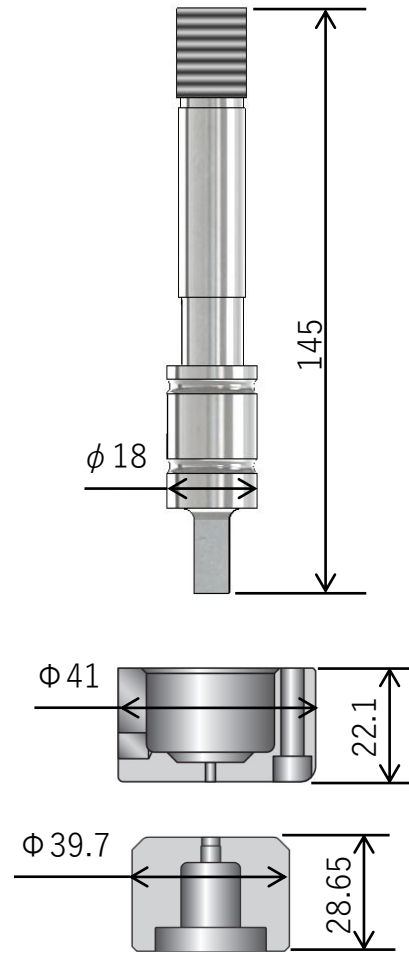
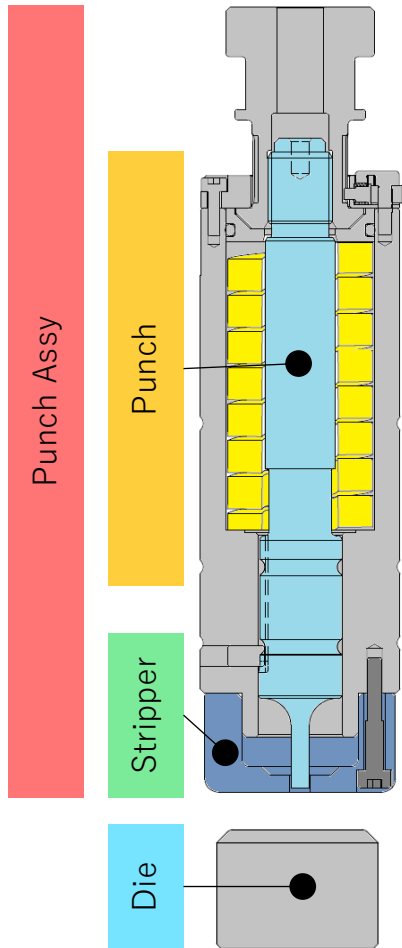

This is a simplified diagram. There may be some differences from the actual shape.

# A,B,I/FB range

Round : ~25  
Rectangle : ~22 (Diagonal)  
Square : ~16  
Oblong : ~25

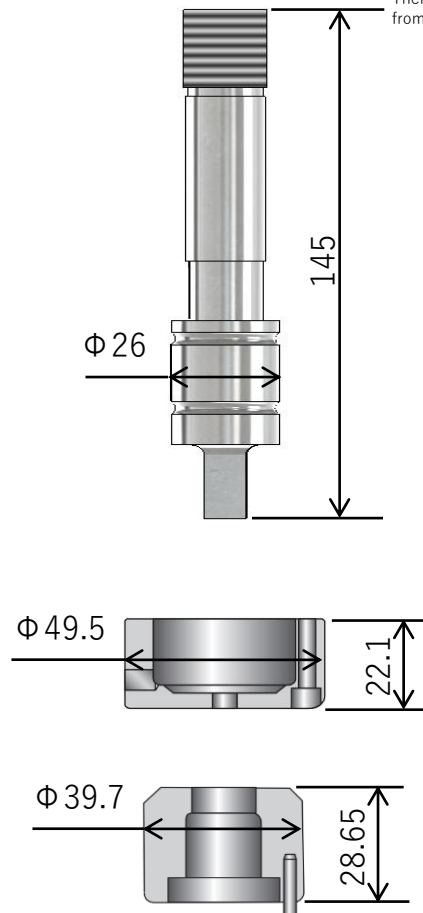
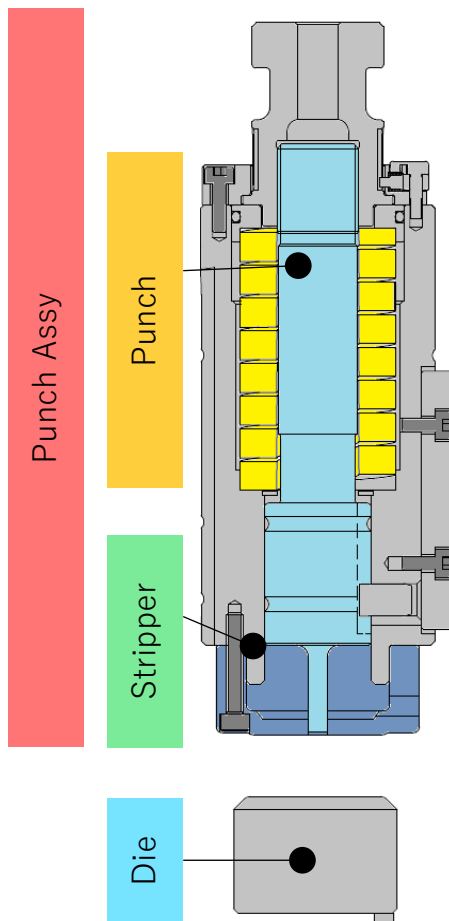

This is a simplified diagram. There may be some differences from the actual shape.

# C,I/FC range

Round : ~38

Rectangle : ~32 (Diagonal)

Square : ~22

Oblong : ~38

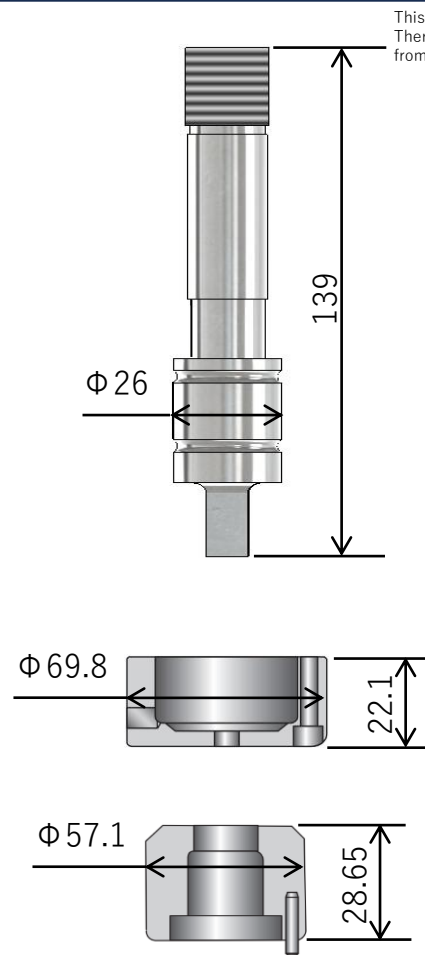
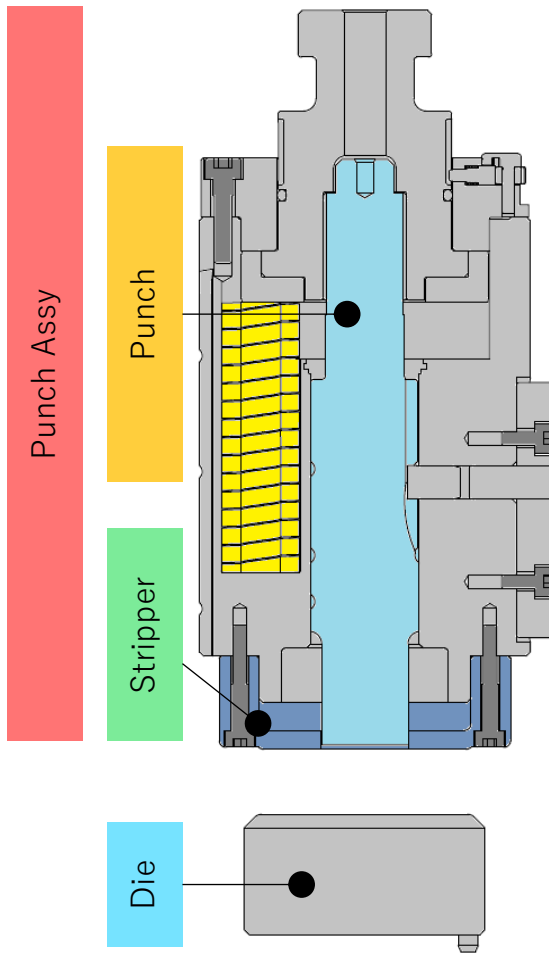

This is a simplified diagram. There may be some differences from the actual shape.

# D,I/FD range

Round : ~50

Rectangle : ~44 (Diagonal)

Square : ~32

Oblong : ~50

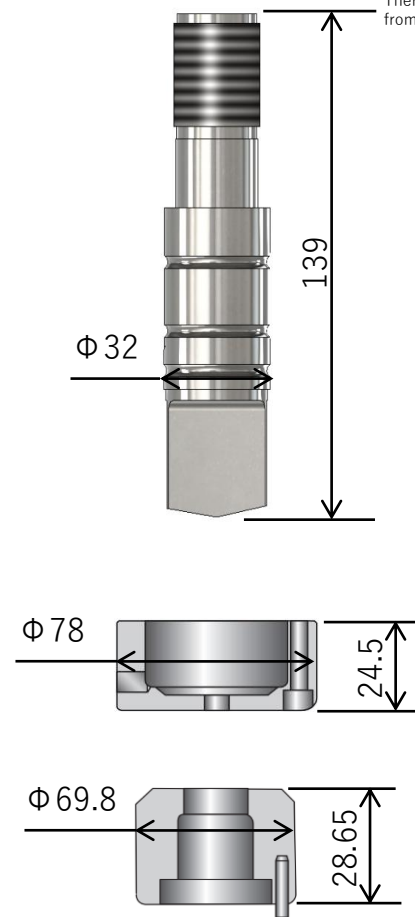
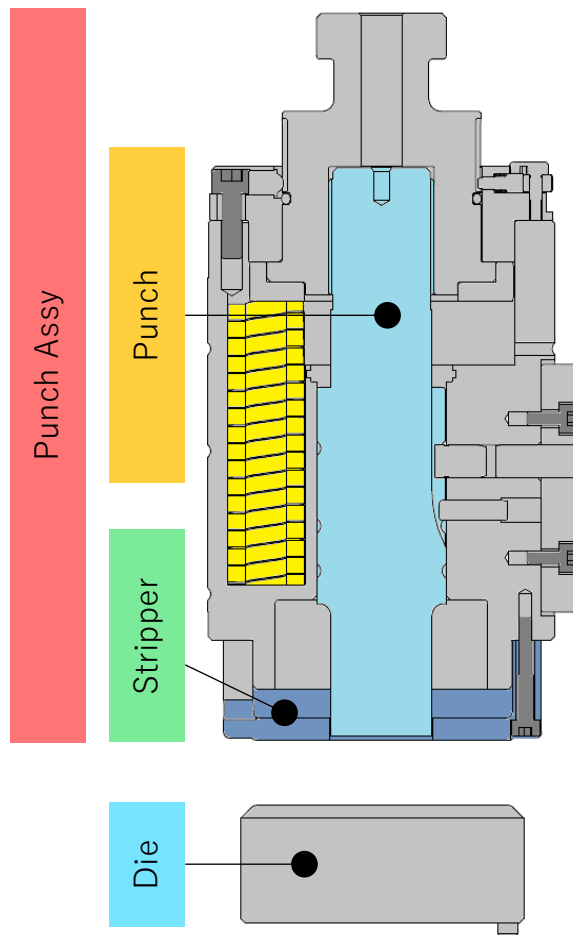

This is a simplified diagram. There may be some differences from the actual shape.

# E range

Round : ~64  
 Rectangle : ~57 (Diagonal)  
 Square : ~41  
 Oblong : ~64

This is a simplified diagram.  
 There may be some differences  
 from the actual shape.

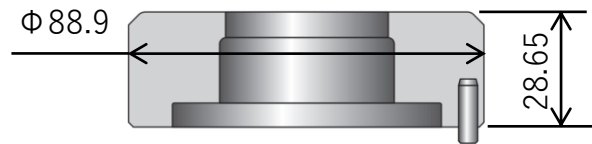
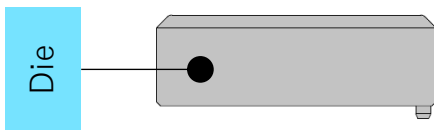
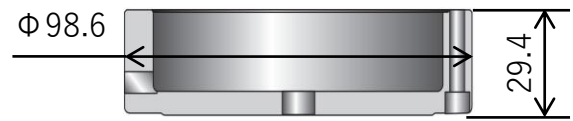
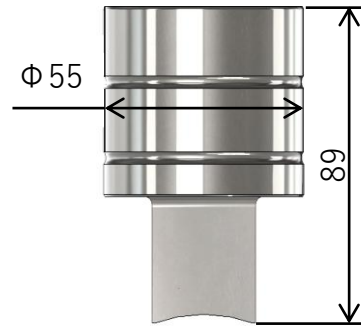
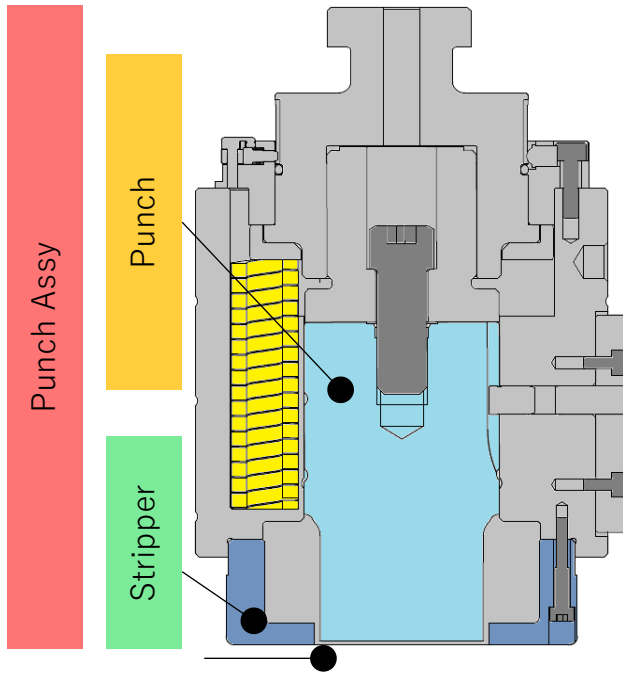

# F,I/F range

Round : ~75  
 Rectangle : ~67 (Diagonal)  
 Square : ~48  
 Oblong : ~75

This is a simplified diagram.  
 There may be some differences  
 from the actual shape.

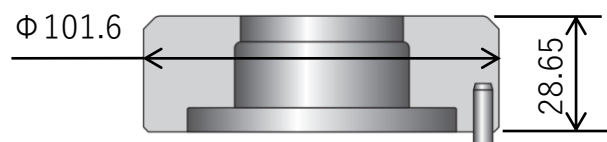
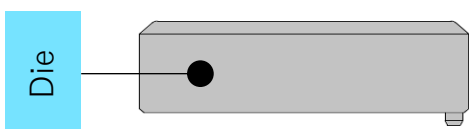
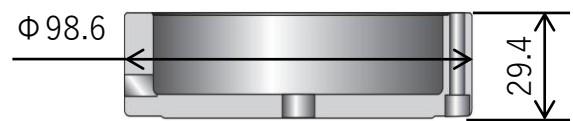
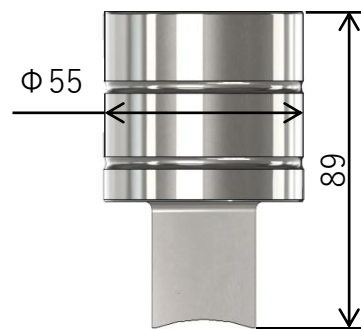
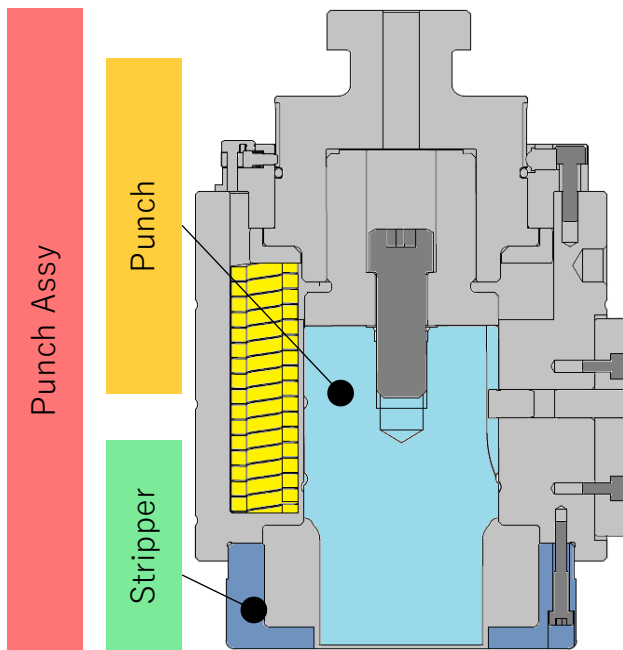

# G range

Round : ~89  
 Rectangle : ~79 (Diagonal)

Square : ~57  
 Oblong : ~89

This is a simplified diagram.  
 There may be some differences  
 from the actual shape.

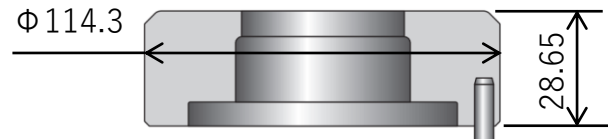
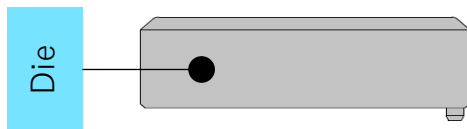
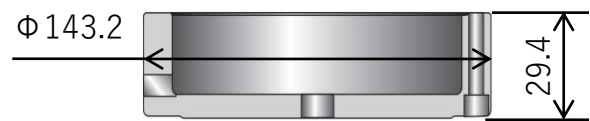
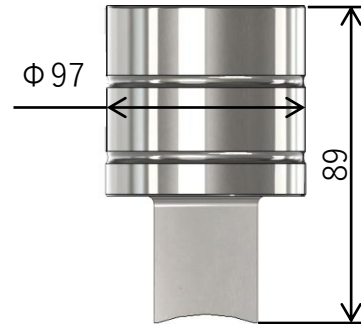
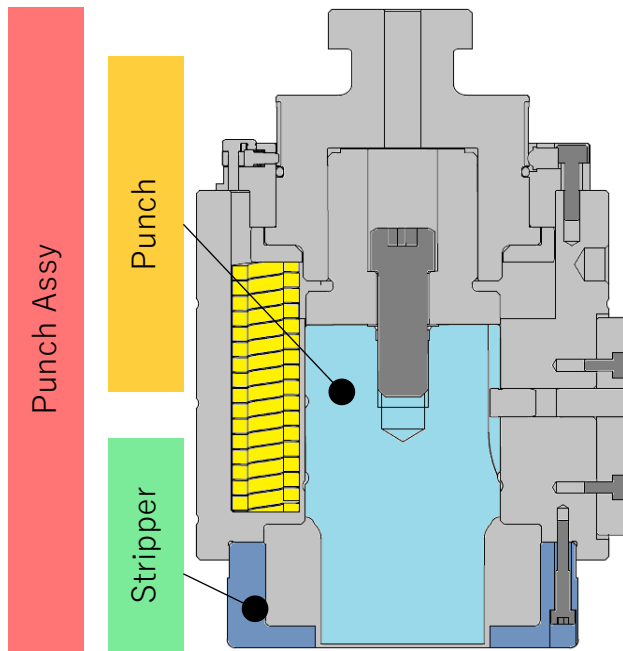

# H range

Round : ~105  
 Rectangle : ~98 (Diagonal)

Square : ~70  
 Oblong : ~105

This is a simplified diagram.  
 There may be some differences  
 from the actual shape.

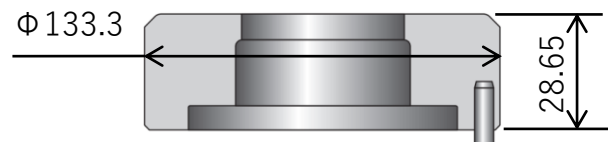
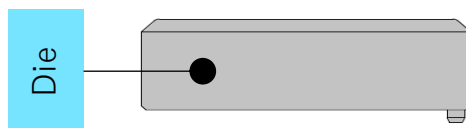
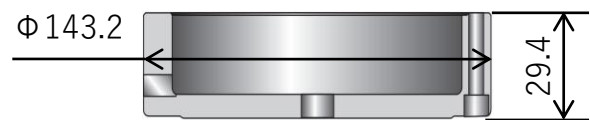
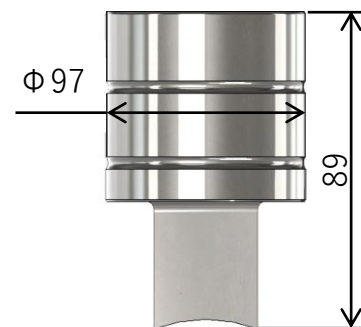
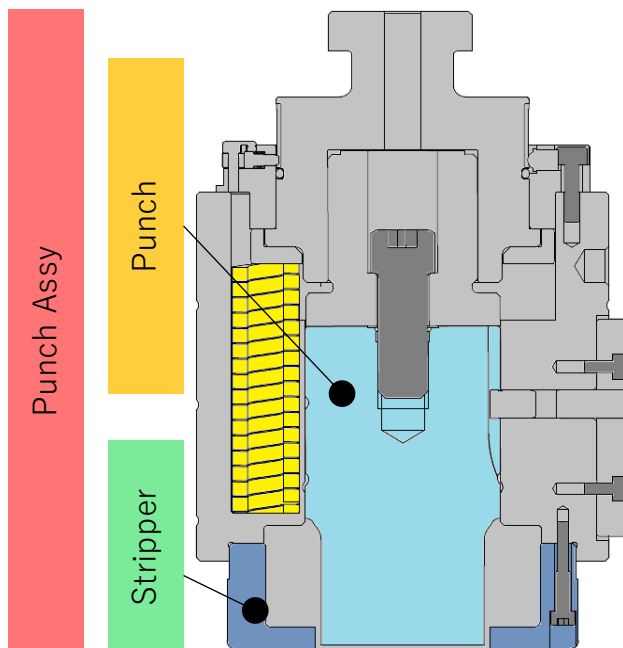

# J range

Round : ~120  
Rectangle : ~113 (Diagonal)

Square : ~79  
Oblong : ~120

This is a simplified diagram.  
There may be some differences  
from the actual shape.

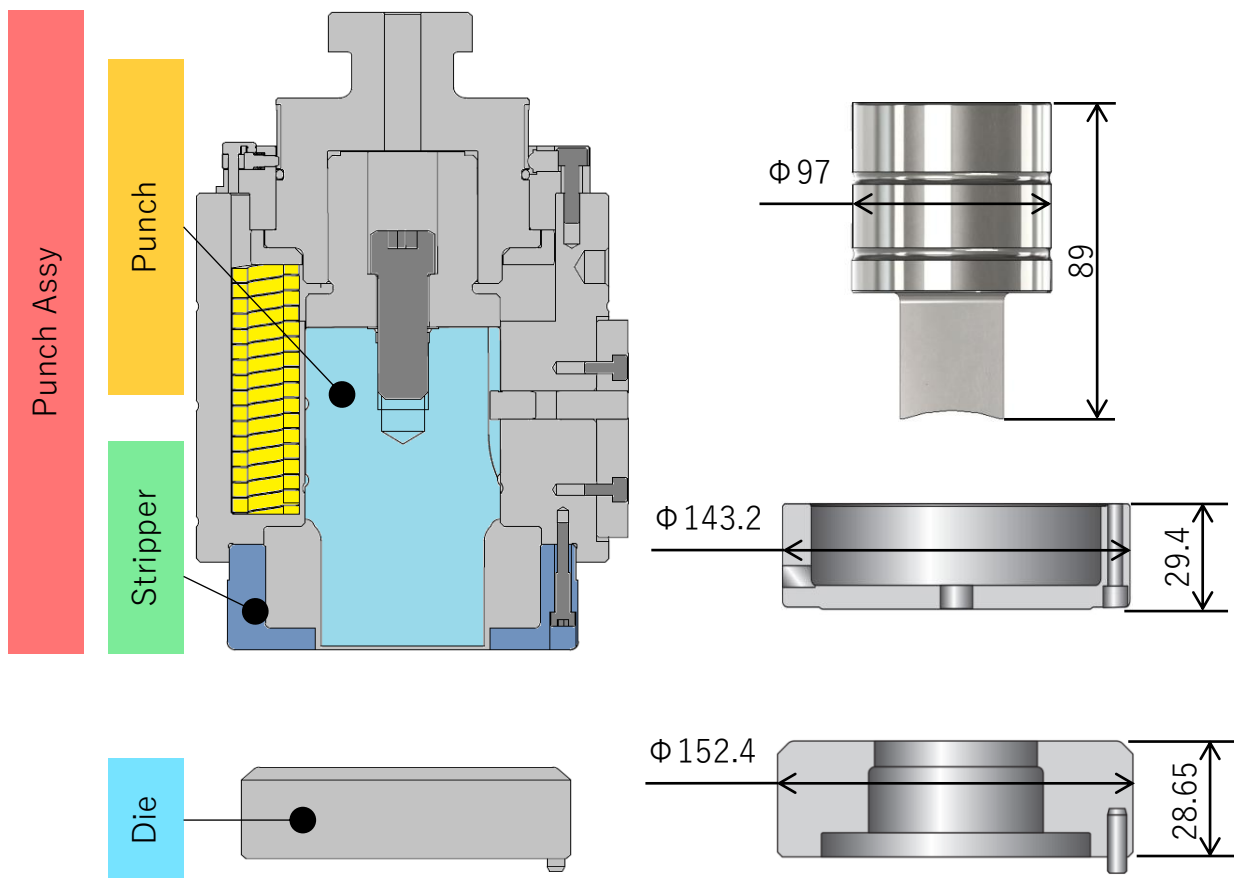

# 12 Multi tool Z

12 Multi tool Z

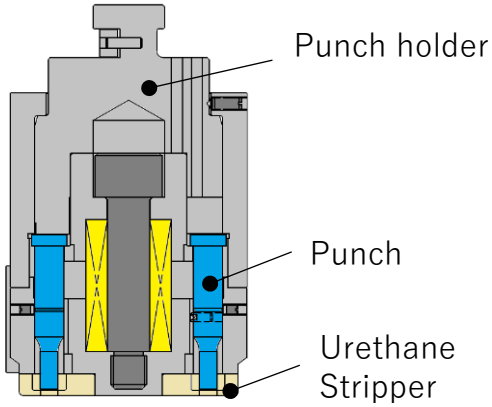

12 Multi tool Z Air

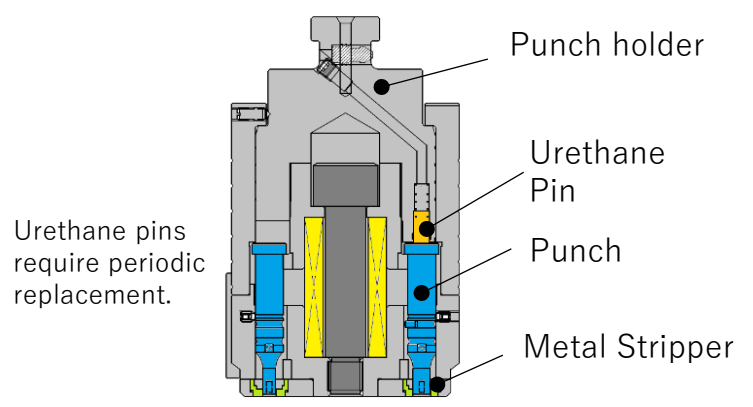

12 Multi tool Z		
Maximum plate thickness	Mild steel:3.2 Stainless:2.0	
Maximum tonnage	4.5ton	
Size	Round	~Φ12.7
	Square	~7.7
	Rectangle	~11.0 (Diagonal)
	Oblong	~12.7

12 Multi tool Z Air		
Maximum plate thickness	Mild steel:4.5 Stainless:3.0	
Maximum tonnage	4.5ton	
Size	Round	~Φ12.7
	Square	~7.7
	Rectangle	~11.0 (Diagonal)
	Oblong	~12.7

- Continuous overlapping punching is not available with the Multi tools.
- Regrinding of punches and dies is not permitted.
- If there is an empty station in the Air type, a flat Die must be placed there.  
(Air leak prevention)

# Work Holder Safety Tool

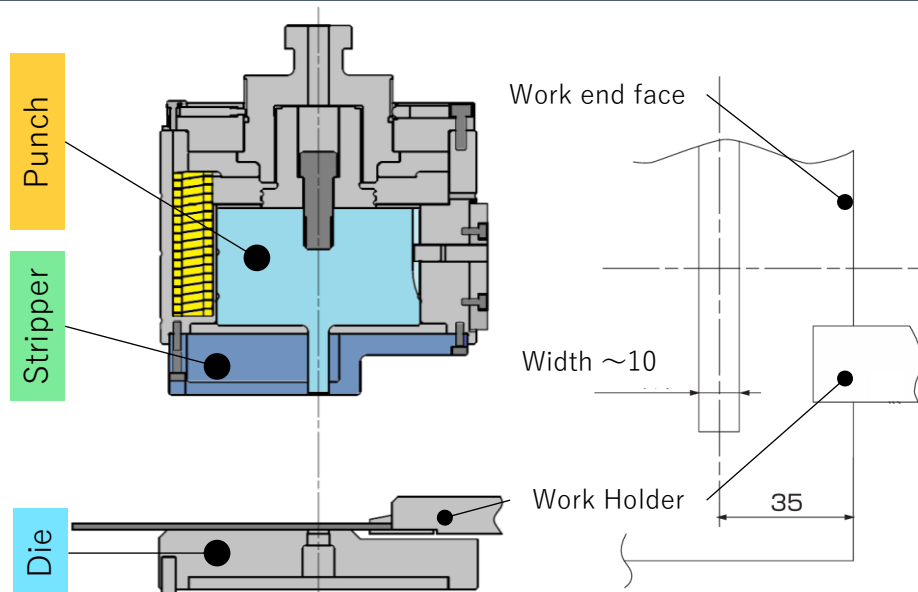

- Work Holder Safety tool Amount of Regrinding : punch 3mm, die 1mm
- The maximum size is 10x100.
- To use this tool, you will need to configure the machine and the Auto Pro software.  
(Only one setting can be configured.)

# Seamless Tool ST-IV

ST-IV is good for a smooth, seamless cutting surface in nibbling operation.  
For the first installation, contact your MURATA sales person for software preparation.

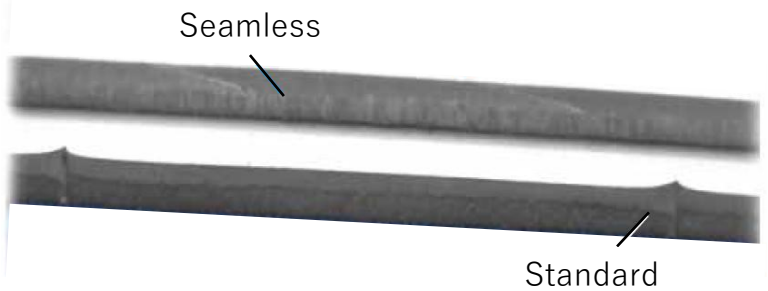
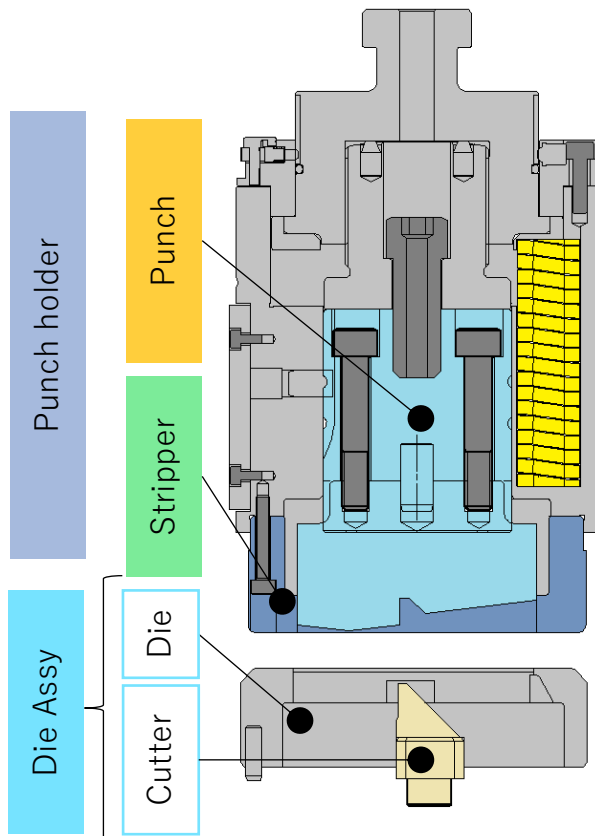

Range: I/F, F

Material/Thickness

Mild steel : t0.8~2.3

Stainless : t0.8~2.0

Aluminum : t0.8~3.0

Tool size: Width 5~10 x 70

A dedicated punch holder is required.

# Smart Slitting Tool

Smart Slitting Tool is another solution for a smoother cut line after nibbling operation.

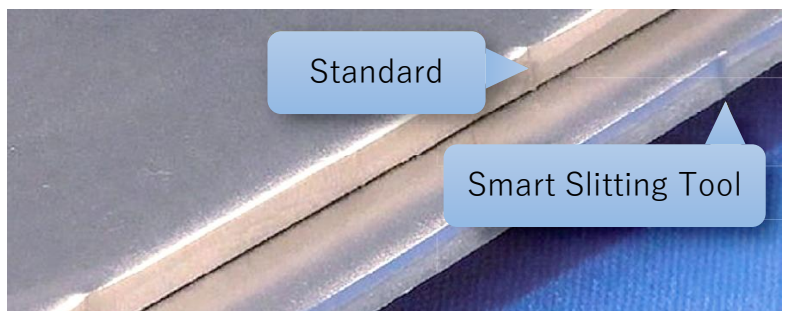
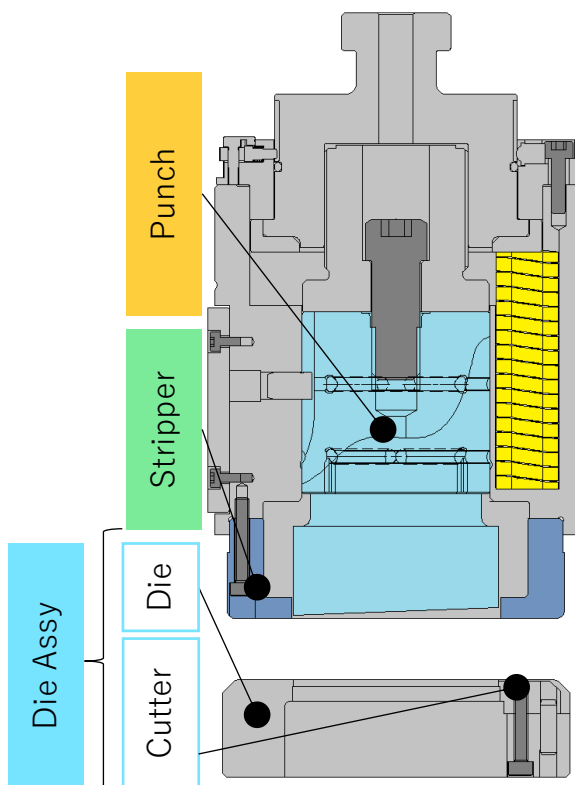

Range: : D~

Material/Thickness

Mild steel : t0.8~6.0

Stainless : t0.8~4.0

Aluminum : t0.8~6.0

Tool length					
D	E	F,I/F	G	H	J
30	40	60	70	80	90

※The die installation direction and processing program must be processed according to our specified procedures.

The die standby position must be raised by 2.4 mm or more from the standard position.

# Fine Nibbling Tool

Eliminates early wear and breakage of punches when nibbling R-shapes or special shapes. The punch is coated with a highly heat-resistant coating, and precision nibbling is now possible with smaller diameters.

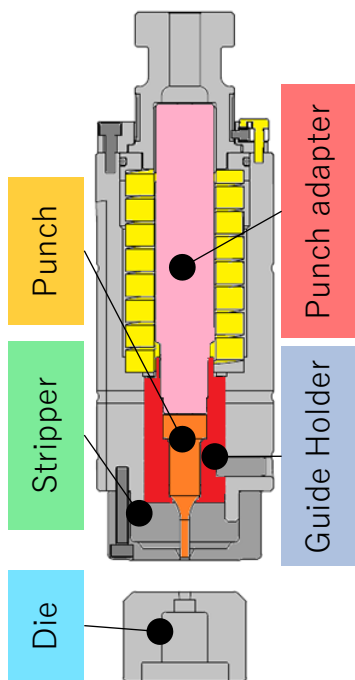

Range: B

Punch size :  $\phi 2 \sim \phi 4$

Material/Thickness

Mild steel (SPCC · SPHC · SECC · SEHC) t0.8~3.2

Stainless (SUS304 · SUS430) t0.8~2.0

Amount of Regrinding : Punch 2.0mm、Die 1.0mm

Recommended Regrinding period : Mild steel 200000HIT  
Stainless 100000HIT

## Minimum punch diameter

Material	t0.8	t1.0	t1.2	t1.6	t2.0	t2.3	t3.2
Mild steel	$\phi 2$	$\phi 2$	$\phi 2$	$\phi 2$	$\phi 3$	$\phi 3$	$\phi 4$
Stainless	$\phi 3$	$\phi 3$	$\phi 4$	$\phi 4$	$\phi 4$	-	-

## Clearance

Material	t0.8	t1.0	t1.2	t1.6	t2.0	t2.3	t3.2
Mild steel	0.15	0.2	0.2	0.2	0.2	0.2	0.3
Stainless	0.15	0.15	0.2	0.2	0.3	-	-

## Minimum processing pitch

Material	t0.8	t1.0	t1.2	t1.6	t2.0	t2.3	t3.2
Mild steel	0.5	0.5	0.5	0.5	0.5	0.5	1.0
Stainless	1.0	1.0	1.0	1.0	1.0	-	-

Only Vulcan II Air is available.

# SHO-KEI Punching Set

The tool is good at piercing an extremely small hole or a too-small-against-the-thickness hole, which so often your punches.

The SHO-KEI punch is made of strong steel and every other part is specially designed to help the fine cutting head penetrate a metal sheet safely.

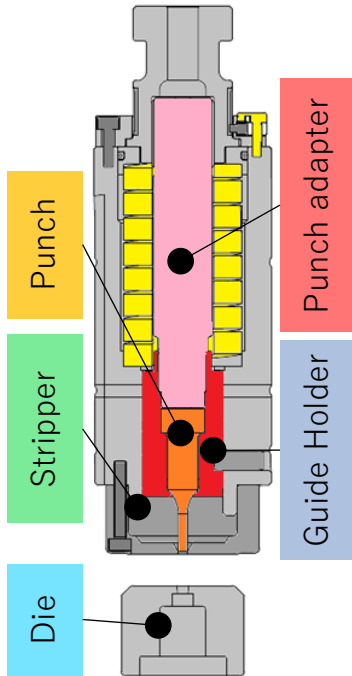

Range: B

- Maximum punch pressure: 5.7 tons (Vulcan II: 4.6 tons)
- Minimum clearance is 0.5 (both sides)  
The die is designed with a cutting blade for thick plates.
- A clearance of 0.5 or less may result in debris on the ring.
- Do not use for nibbling.  
Punch cannot be sharpened.
- The processing conditions and processing pattern must be changed for each material.  
( Mild steel : Forming    Stainless : Seamless    Aluminum : Punch)

Material	Thickness	Size		Ratio of punch size to plate thickness	
		VULCAN II	VULCAN II Air	VULCAN II	VULCAN II Air
Mild steel aluminum	~6.3	$\phi 1.6 \sim \phi 6.0$	$\phi 1.5 \sim \phi 9.99$	$t \times 0.6$	$t \times 0.42$
SS400					$t \times 0.54$
Stainless				$t \times 1.1$	$t \times 0.96$

# SHO-KEI Punching Set Punch assembly procedure

## Punch assembly procedure

- 1) Insert the punch ③ into the tapered ring ②.
- 2) ① Apply "medium-strength anaerobic adhesive" to the red-lined thread of the punch adapter. Recommended adhesive: Loctite 243
- 3) ④ Attach to the guide holder.

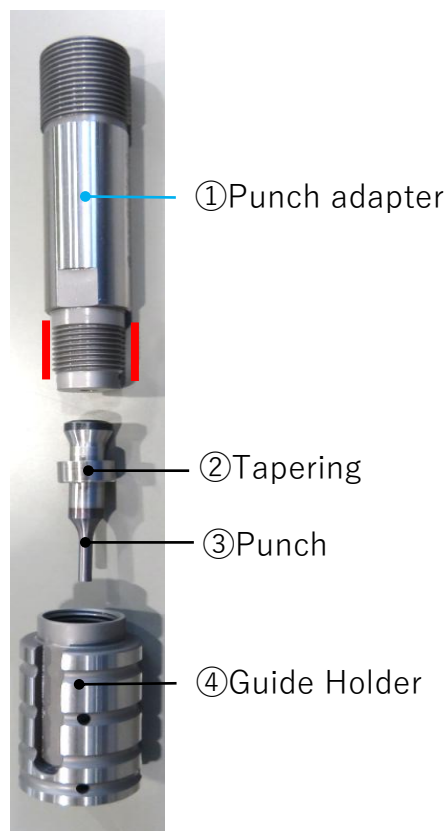

- 4) ⑤ Fix the jig in a vise or similar and set the punch Assy.

⑤ Jig



- 5) Use a wrench (17 mm) to tighten the punch adapter (1) to approximately 20 N m. After tightening, leave it for about 15 minutes until the adhesive hardens. 20N/m means that the screw has been tightened by 5° from the point where it no longer tightens.



- 6) Release the rotation lock of the punch holder, set the punch Assy and adjust the height.
- 7) Lock the rotation lock of the punch holder, attach the stripper, and tighten the stripper bolt.

⑥ Spanner

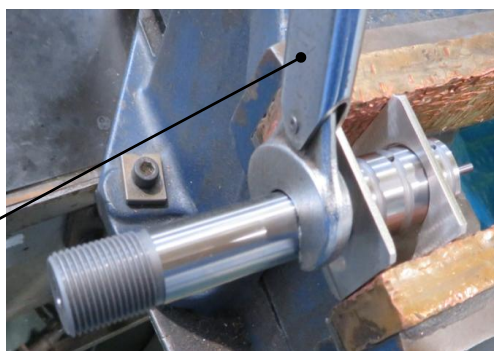

# Marking Tool

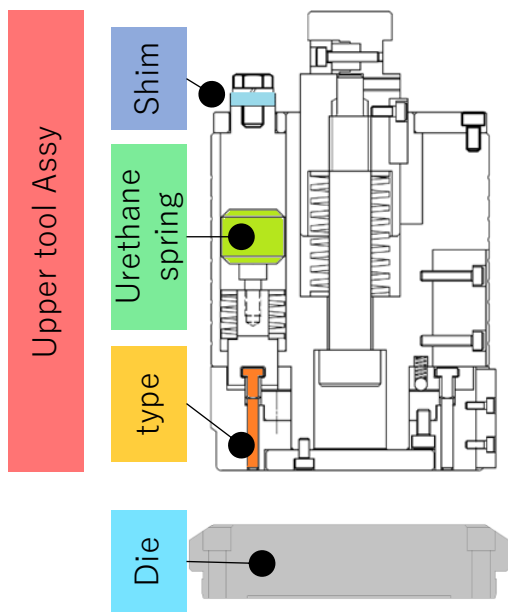

Range: I/F

	Type	
	20 character	40 character
Marking character	A~Z 26kinds 0~9 10kinds / + - . 4kinds ※ Select 20 characters from the above	A~Z 26kinds 0~9 10kinds / + - . 4kinds ※ Select 40 characters from the above
Character size	5 × 3.2	3.2 × 2.1
Thickness	t0.8~6.3	

※ / (Slash) + (Plus) - (Minus) . (Period)

• Please choose either 20 or 40 characters.

• By changing the adjustment shim, it can be processed from t0.8 to t6.3.

t0.8~2.7 : Shim 3pieces

t2.8~4.4 : Shim 2pieces

t4.5~5.9 : Shim 1pieces

t6.0~6.3 : No Shim

# FP Punch holder

FP is an abbreviation for forming punch, and is a punch holder exclusively for upward forming.

The height of the upper die can be adjusted Shim less.

By turning the tang, the overall length can be extended or retracted, eliminating the need for cumbersome shim insertion.

## Height adjustment method

The punch height must be set depending on the model used and the type of molding. (This is shown on the drawing.)

- 1) ② Loosen all the bolts.  
For the B and C ranges, insert the included jig rod into the jig rod insertion hole next to the punch holder ③, secure it so that the body does not rotate, and then loosen it.

【Jig rod】

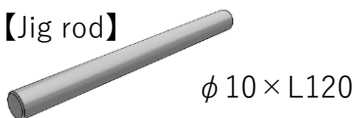

- 2) ① Rotate the tongue and set the L dimension of the model using the punch height to the minimum value.  
① When looking at the tang from above, rotating it clockwise shortens the punch height and rotating it counterclockwise lengthens the punch height.  
① Tongue ② Bolts (M8 × 30) ③ Punch holder

- 3) Tighten with a tightening torque of 30 N·m.

※The molds vary depending on the plate thickness and material.  
Please use the dedicated mold within the applicable range.

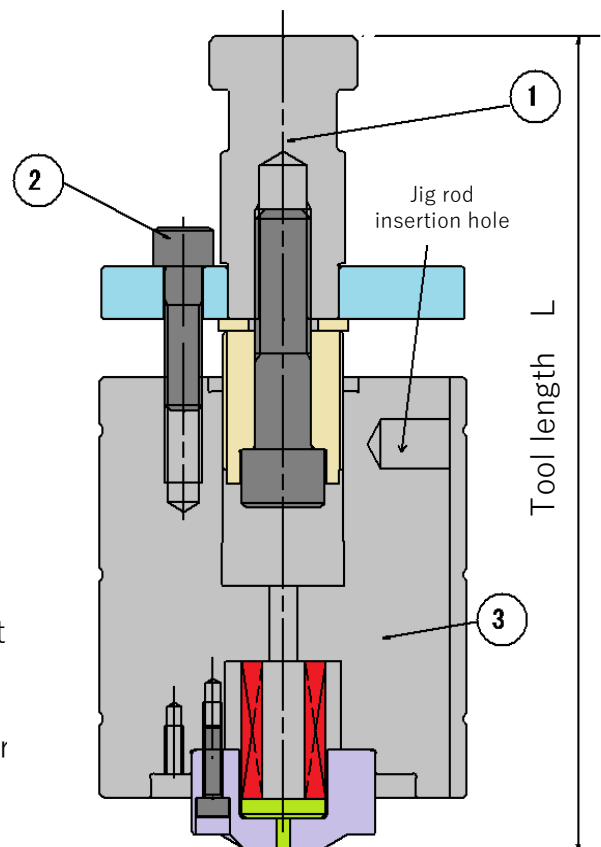

# Burring

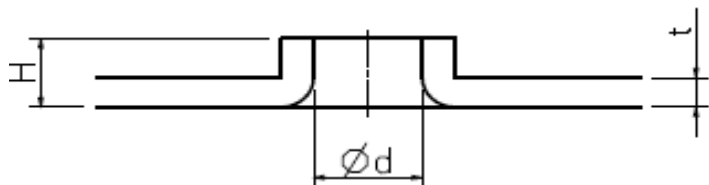

- When ordering, please let us know the material, plate thickness, pitch, whether it is for cutting or rolling, and the  $\Phi d$  dimension.
- Pilot hole is needed.
- The height  $H$  dimension varies depending on the pilot hole dimensions.
- Range : C (Upward)  
B (Downward)

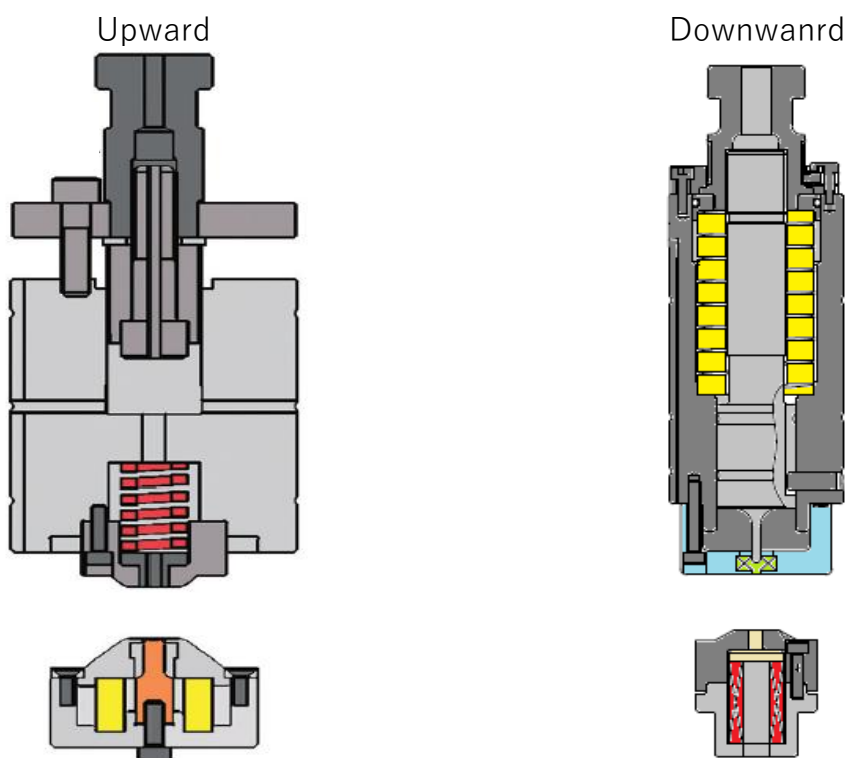

Punch diameter

	Material	M3	M4	M5	M6
Cutting	Mild steel/Aluminum	$\Phi 2.57$	$\Phi 3.39$	$\Phi 4.31$	$\Phi 5.13$
	Stainless				
Rolling	Mild steel/Aluminum	$\Phi 2.74$	$\Phi 3.64$	$\Phi 4.56$	$\Phi 5.46$
	Stainless	$\Phi 2.76$	$\Phi 3.67$	$\Phi 4.60$	$\Phi 5.50$

Sheet thickness range

	M3	M4	M5	M6
Mild steel Aluminum	t0.6~1.6	t0.8~1.6	t0.8~1.6	t1.0~1.6
	-	t1.5~2.3	t1.5~2.3	t1.5~2.3
Stainless	t0.8~1.0	t0.8~1.0	t0.8~1.2	t1.0~1.2
	t1.0~1.5	t1.0~1.5	t1.2~1.5	t1.2~1.5
	-	t2.0	t2.0	t2.0

# Burring

## Pilot hole diameter Cutting

Material	Thickness	M3		M4		M5		M6	
		Pilot hole	Hight	Pilot hole	Hight	Pilot hole	Hight	Pilot hole	Hight
Mild steel Aluminum	0.6	Φ1.2	1.5	-	-	-	-	-	-
	0.8	Φ1.5	1.5	Φ1.3	2.1	Φ2.2	2.4	-	-
	1.0	Φ1.6	1.6	Φ1.5	2.1	Φ2.6	2.4	Φ2.2	3.0
	1.2	Φ1.8	1.9	Φ1.8	2.1	Φ3.0	2.4	Φ2.6	3.0
	1.5	Φ1.8	2.6	Φ2.3	2.6	Φ3.5	2.6	Φ3.2	3.0
	1.6	Φ1.8	2.7	Φ2.1	2.7	Φ3.1	2.7	Φ3.5	3.0
	2.0	-	-	Φ2.2	3.4	Φ3.4	3.4	Φ3.6	3.4
	2.3	-	-	Φ2.2	3.9	Φ3.3	3.9	Φ3.6	3.9
Stainless	0.8	Φ1.7	1.5	Φ1.5	2.1	Φ2.4	2.4	-	-
	1.0	Φ1.9	1.6	Φ1.9	2.1	Φ2.4	2.4	Φ2.2	3
	1.2	Φ1.9	1.9	Φ2.4	2.1	Φ2.4	2.4	Φ2.7	3
	1.5	Φ1.6	2.6	Φ2.3	2.6	Φ2.6	2.6	Φ3.3	3
	2.0	-	-	Φ2.0	3.4	Φ3.4	3.4	Φ3.6	3.4

## Rolling

Material	Thickness	M3		M4		M5		M6	
		Pilot hole	Hight	Pilot hole	Hight	Pilot hole	Hight	Pilot hole	Hight
Mild steel Aluminum	0.6	Φ1.4	1.5	-	-	-	-	-	-
	0.8	Φ1.7	1.5	Φ1.5	2.1	Φ1.9	2.4	-	-
	1.0	Φ1.7	1.6	Φ1.9	2.1	Φ2.4	2.4	Φ2.6	3.0
	1.2	Φ1.9	1.9	Φ2.1	2.1	Φ2.9	2.4	Φ3.4	3.0
	1.5	Φ1.9	2.6	Φ2.5	2.6	Φ3.4	2.6	Φ3.7	3.0
	1.6	Φ1.9	2.7	Φ2.5	2.7	Φ3.6	2.7	Φ4.2	3.0
	2.0	-	-	Φ2.7	3.4	Φ3.9	3.4	Φ4.2	3.4
	2.3	-	-	Φ2.7	3.9	Φ3.9	3.9	Φ4.2	3.9
Stainless	0.8	Φ1.6	1.5	Φ1.7	2.1	Φ2.4	2.4	-	-
	1.0	Φ1.6	1.6	Φ1.9	2.1	Φ2.6	2.4	Φ2.5	3.0
	1.2	Φ1.8	1.9	Φ2.2	2.1	Φ3.3	2.4	Φ3.1	3.0
	1.5	Φ1.9	2.6	Φ2.6	2.6	Φ3.6	2.6	Φ3.6	3.0
	2.0	-	-	Φ2.4	3.4	Φ3.2	3.4	Φ4.1	3.4

# Burring

## Minimum processing pitch

	Material	M3		M4		M5		M6	
		Thickness	Pitch	Thickness	Pitch	Thickness	Pitch	Thickness	Pitch
Cutting	Mild steel Aluminum	t0.6~1.6	13	t0.8~1.6	14	t0.8~1.6	14	t1.0~1.6	15
		-	-	t1.5~2.3	14	t1.5~2.3	14	t1.5~2.3	15
	Stainless	t0.8~1.0	12	t0.8~1.0	13	t0.8~1.2	14	t1.0~1.2	15
		t1.0~1.5	13	t1.0~1.5	13	t1.2~1.5	14	t1.2~1.5	51
		-	-	t2.0	14	t2.0	14	t2.0	15
Rolling	Mild steel Aluminum	t0.6~1.6	13	t0.8~1.6	14	t0.8~1.6	15	t1.0~1.6	15
		-	-	t1.5~2.3	15	t1.5~2.3	15	t1.5~2.3	15
	Stainless	t0.8~1.0	12	t0.8~1.0	13	t0.8~1.2	14	t1.0~1.2	15
		t1.0~1.5	12	t1.0~1.5	13	t1.2~1.5	14	t1.2~1.5	15
		-	-	t2.0	14	t2.0	14	t2.0	15

# High speed marking

Dotted lines are stamped on the material, and letters and logos are mark at high speed.  
(Top surface only)

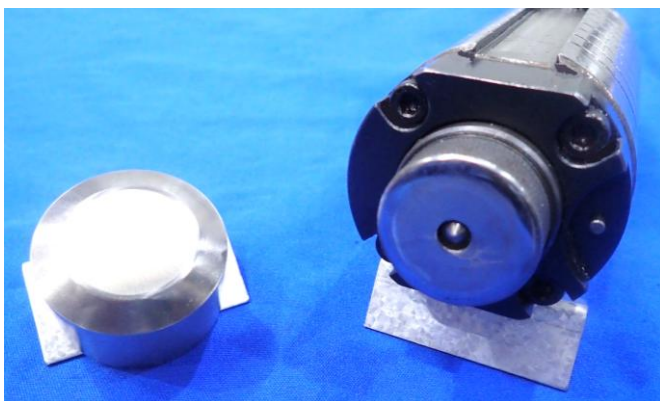

Range: B

Thickness  
0.8~6.0

Compatible models  
FANUC 31i NC unit

For CAMPATH

With the dot marking option, you can easily engrave letters and other characters.

# Center punch(Top marking)

This is an adjustable type that allows you to adjust the cutting edge extension.

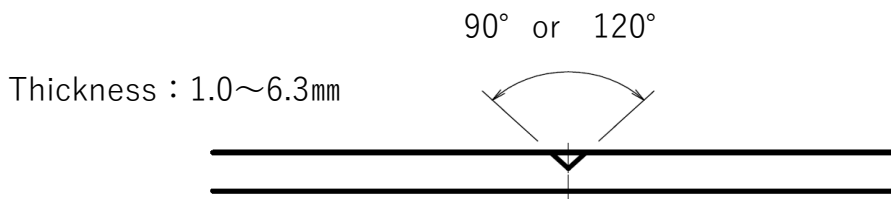

Maximum marking diameter

Range	Mild steel	Aluminum	Stainless
X	Φ 2.1	Φ 2.6	Φ 1.4
A B	Φ 2.4	Φ 2.8	Φ 1.6

Punch

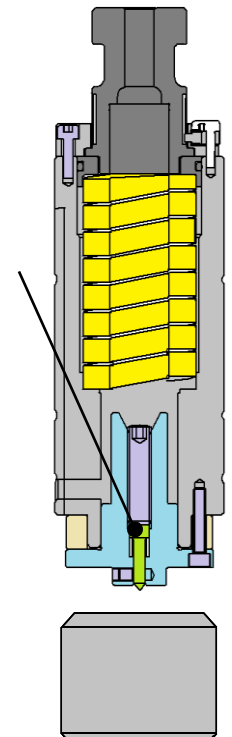

When ordering, please let us know the material, plate thickness, and angle ( $\alpha$ ).

Select angle  $\alpha$  as either  $90^\circ$  or  $120^\circ$ .

The forming depth should be 1/2 or less of the plate thickness.

# Center punch(Bottom marking)

This is an adjustable type that allows you to adjust the cutting edge extension

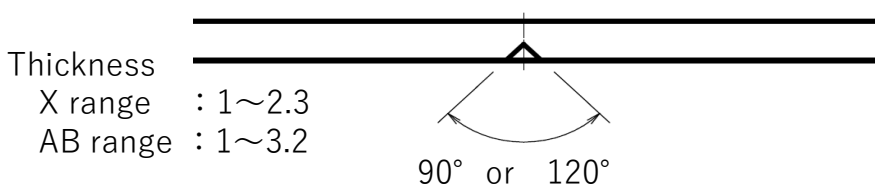

Maximum marking diameter

Range	Mild steel	Aluminum	Stainless
X	Φ 1.5	Φ 1.7	Φ 1.3
A B	Φ 1.8	Φ 1.8	Φ 1.5

Punch

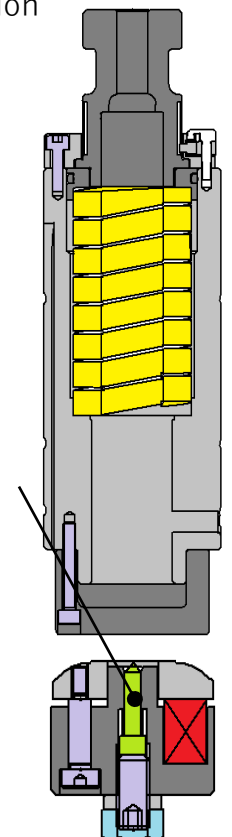

When ordering, please let us know the material, plate thickness, and angle ( $\alpha$ ).

Select angle  $\alpha$  as either  $90^\circ$  or  $120^\circ$ .

The forming depth should be 1/2 or less of the plate thickness.

There are two types for the underside: standard and low height.

For low height tool, the maximum plate thickness is t2.3.

# Locater Point

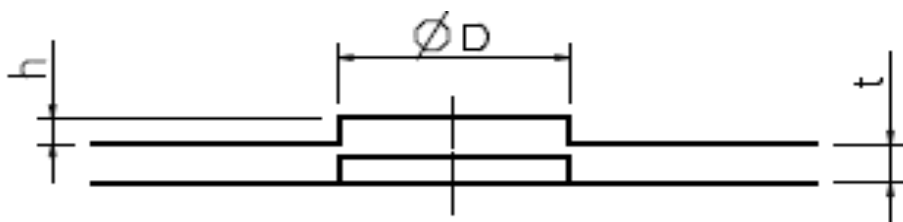

- When ordering, please let us know the material, plate thickness, pitch, and  $\phi D$  dimensions.
- The height  $h$  is less than half the plate thickness.

Forming direction	Range	$\phi D$ (max)
Upward	B	6
Upward	C	12
Downward	B	8

# Positioning

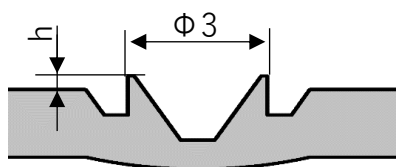

Thickness	h	
	Mild steel	Aluminum
0.8	0.31	0.29
1.0	0.39	0.30
1.2	0.35~0.41	0.33
1.5	-	0.38
1.6	0.34~0.37	-
2.0	-	0.39
2.3	0.34~0.36	-



Molded convex side



Molded flat side

- The above table is an experimental value.  
The amount may vary depending on the material lot, etc.
- Only mild steel and aluminum materials can be used.
- The protrusions are formed in two Process. 2 tool is required.  
(A bulge of about  $20 \mu\text{m}$  occurs on the backside)
- Range : B (Top punching)  
C (Bottom punching)

# Coined Countersink

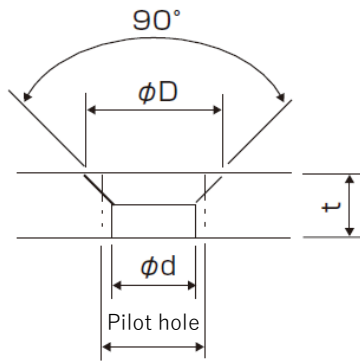

- When ordering, please let us know the plate thickness, material, and head diameter of the countersunk screws.
- Please let us know if it is for the top or bottom.

## Outer diameter ( $\phi D$ )

M2	M2.3	M2.6	M3	M4	M5	M6
$\phi 4.5$	$\phi 5.1$	$\phi 5.7$	$\phi 6.6$	$\phi 8.7$	$\phi 10.8$	$\phi 13$

## Inner diameter ( $\phi d$ )

When the thickness of the material is smaller than the height of the countersink or when there is a large distortion on the back surface during countersinking, the inner diameter is made larger.

## Sheet thickness range

Material	M2	M2.3	M2.6	M3	M4	M5	M6
Mild steel Aluminum	t1.0	t1.0	t1.0	t1.0~1.2	t1.5~1.6	t1.5~1.6	t2.0~2.3
	t1.2~2.3	t1.2	t1.2	t1.5~1.6	t2.0	t2.0~2.3	t3.0~3.2
	-	t1.5~2.3	t1.5~2.3	t2.0~2.3	t2.3~3.2	t3.0~3.2	-
Stainless	t1.0	t1.0~1.2	t1.0~1.2	t1.0~1.5	t1.5~2.0	t1.5~2.0	t2.0
	t1.2~2.0	t1.2	t1.5~2.0	t2.0	t3.0	t3.0	t3.0
	-	t1.5~2.0	-	-	-	-	-

By changing the lower die, it is possible to process outside the plate thickness range.

## Usable range

Range	Mild steel	Aluminum	Stainless
X	~M5	~M6	~M3
AB	~M6	~M6	~M5
C	~M6	~M6	~M6

Due to mold pressure restrictions, there is a maximum size for each material at each station.

# Coined Countersink

Pilot hole diameter

Material	Thickness (t)	M2		M2.3		M2.6		M3	
		$\phi D = \phi 4.5$		$\phi D = \phi 5.1$		$\phi D = \phi 5.7$		$\phi D = \phi 6.6$	
		Pilot hole	$\phi d$	Pilot hole	$\phi d$	Pilot hole	$\phi d$	Pilot hole	$\phi d$
Mild steel Aluminum	1.0	3.4	3.2	4.0	3.7	4.5	4.2	5.4	5.2
	1.2	3.1	2.7	3.7	3.3	4.3	4.2	5.4	5.1
	1.5	3.0	2.6	3.4	2.8	3.7	3.2	4.8	4.2
	1.6	3.0	2.6	3.5	3.1	3.7	3.2	4.5	4.0
	2.0	2.9	2.5	3.7	3.1	3.7	3.2	4.5	3.8
	2.3	3.1	2.5	3.5	3.1	3.7	3.1	4.3	3.7
Stainless	1.0	3.2	3.2	3.6	3.5	4.3	4.4	5.2	5.3
	1.2	3.0	2.9	3.4	3.5	4.4	4.4	5.3	5.3
	1.5	2.8	2.6	3.4	3.3	4.4	3.9	5.2	5.1
	2.0	2.7	2.5	3.4	3.3	4.0	3.9	4.9	4.8

Material	Thickness (t)	M4		M5		M6	
		$\phi D = \phi 8.7$		$\phi D = \phi 10.8$		$\phi D = \phi 13$	
		Pilot hole	$\phi d$	Pilot hole	$\phi d$	Pilot hole	$\phi d$
Mild steel Aluminum	1.5	6.9	6.1	9.1	8.5	-	-
	1.6	6.6	6.0	9.0	8.5	-	-
	2.0	6.4	5.5	8.0	7.2	10.5	9.6
	2.3	6.2	5.5	8.0	7.3	10.5	9.8
	3.0	5.9	4.7	7.5	6.5	9.4	8.6
	3.2	5.7	4.6	7.3	6.3	8.9	8.5
Stainless	1.5	6.9	7.1	8.7	9.0	-	-
	2.0	6.4	6.8	8.2	8.7	10.6	10.5
	3.0	6.1	6.2	8.3	8.3	10.1	10.4

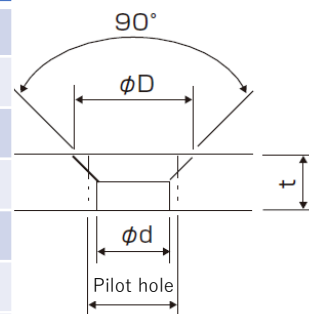

※The above table shows reference values after drilling holes using a press.  
The height includes the plate thickness.  
(This may vary depending on the material used by the customer.)

# Emboss

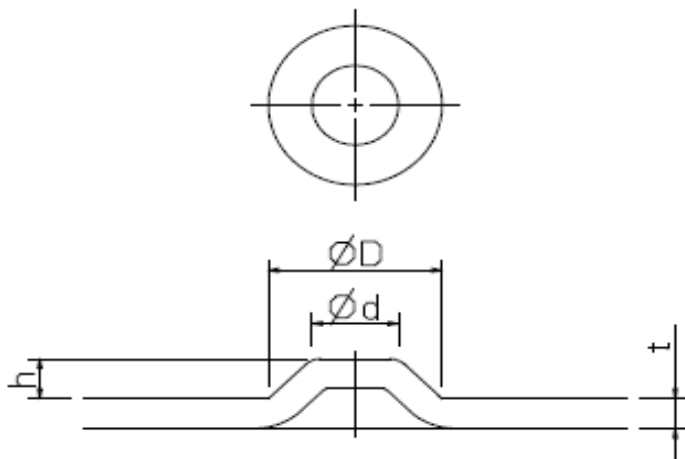

When ordering, please let us know the direction, plate thickness, material,  $\phi D$ ,  $\phi d$ , height (h) and pitch if required.

# Countersink

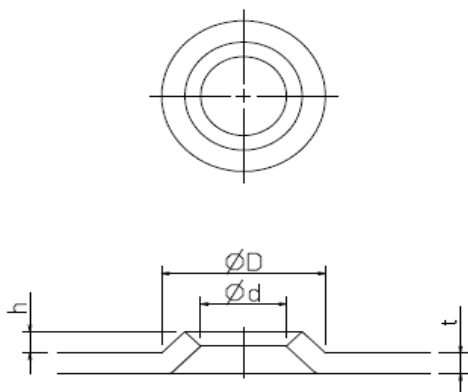

When ordering, please let us know the direction, plate thickness, material,  $\phi D$ ,  $\phi d$ , height (h) and pitch if required.

Upward

Forming	Range	$\phi D$ (mm)
Emboss Countersink	B	~ $\phi 8$
	C	~ $\phi 14$
	D	~ $\phi 23$
	E	~ $\phi 29$
	F	~ $\phi 33$
	G	~ $\phi 55$
	H	~ $\phi 64$
	J	~ $\phi 74$

# Knockout

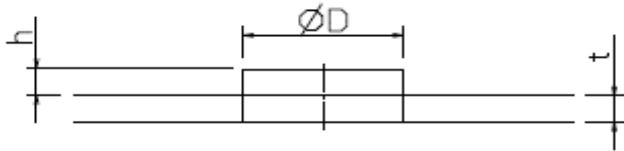
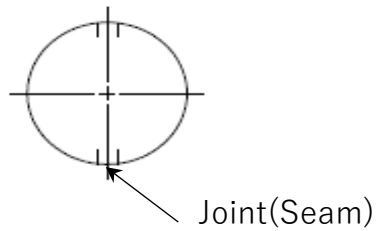

When ordering, please let us know the orientation, plate thickness, material,  $\phi D$ , number of joints (position), and pitch if required.

Upward

Range	$\phi D$ (mm)
B	~ $\phi 8$
C	~ $\phi 14$
D	~ $\phi 23$
E	~ $\phi 29$
F	~ $\phi 33$
G	~ $\phi 55$
H	~ $\phi 64$
J	~ $\phi 74$

# Engraved/logo mark



When ordering, please let us know the molding direction, plate thickness, material, size, and height. Complex shapes require CAD data.

# Bridge

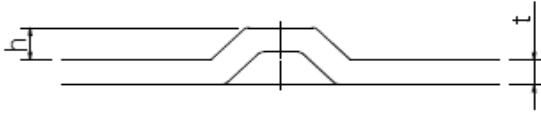
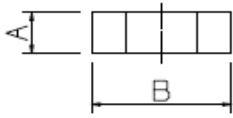

When ordering, please let us know the direction, plate thickness, material, A, B, and height (h).

Upward

Forming	Range	A × B (mm)
Single Bridge	C	~5 × 12
	D	~7 × 23
Double Bridge	C	~5 × 12
	D	~7 × 23

# Lance

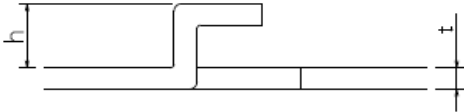
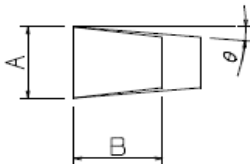

When ordering, please let us know the plate thickness, material, A, B, and height (h). We recommend that  $\theta$  be  $5^\circ$  or more (to prevent the upper die from getting caught).

Upward

Range	A × B (mm)
D	~10 × 22
E	~15 × 44
F	~17 × 55
G	~17 × 64
H	~20 × 77
J	~20 × 100

# Bead

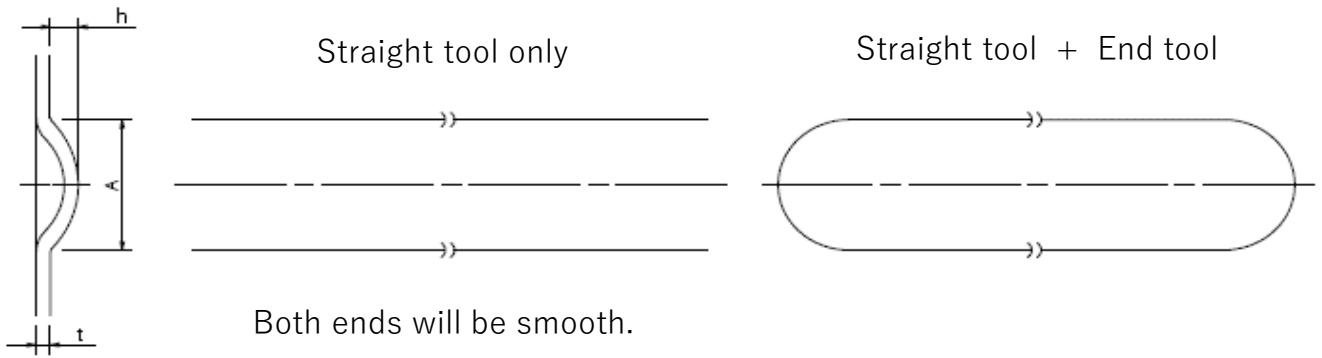

- When ordering, please let us know the orientation, thickness, material, width (A), and height (h).
- The straight type is followed by punching at 2mm intervals, leaving punch marks.
- If you only use the straight type, both ends will be smooth (it will not be oval).

## Upward

Range	A (mm)
C	~6
D	~10
E	~16
F	~20
G	~26
H	~32
J	~40

# Louver

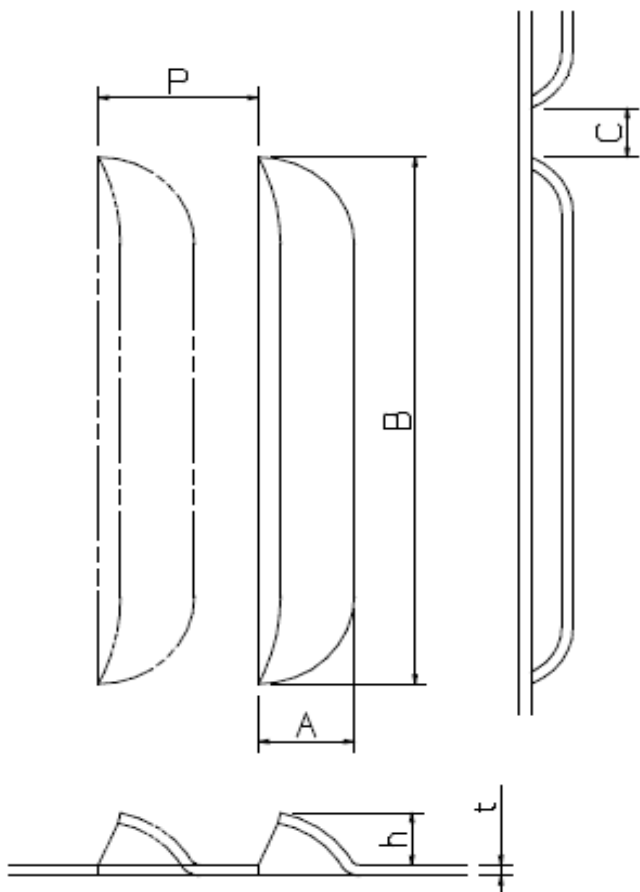

- When ordering, please let us know the plate thickness, material, A, B, C, h, and P.
- A molding distance (P-A) of 10 mm or more is recommended.
- The maximum height, including plate thickness, is 10 mm.  
However, h (step) must be 60% or less of A (width).  
Example: A (width) 10, h (step) 6 or less

## Upward

Range	A × B (mm)
D	~10 × 22
E	~15 × 44
F	~17 × 55
G	~17 × 64
H	~20 × 77
J	~20 × 100

# Forming Tool UP/DOWN

UP/DOWN Forming Tool is designed to be retractable when necessary. While a work is traversing, the lower part stays flush with the surrounding surface and pops up only when the punch strikes. There is less friction between the work and the part, and thus, less scratches are found on the backside of the sheet.

## Mechanism

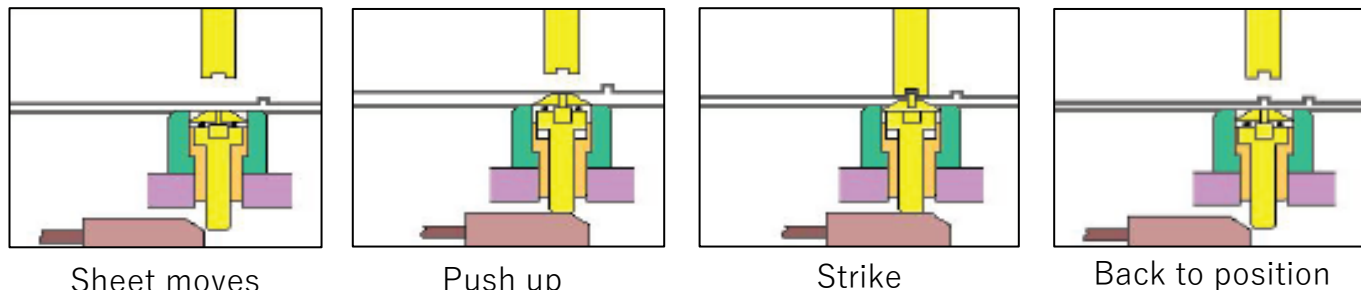

Sheet moves

Push up

Strike

Back to position

## Lower die installation method

- Remove the set screw ③ on the die holder ①.
- Place the lower die through the upper turret, supporting it with a brass rod or similar. EF stations and above have gripping jigs (optional).
- Attach the lower die while checking the position of the ② key.

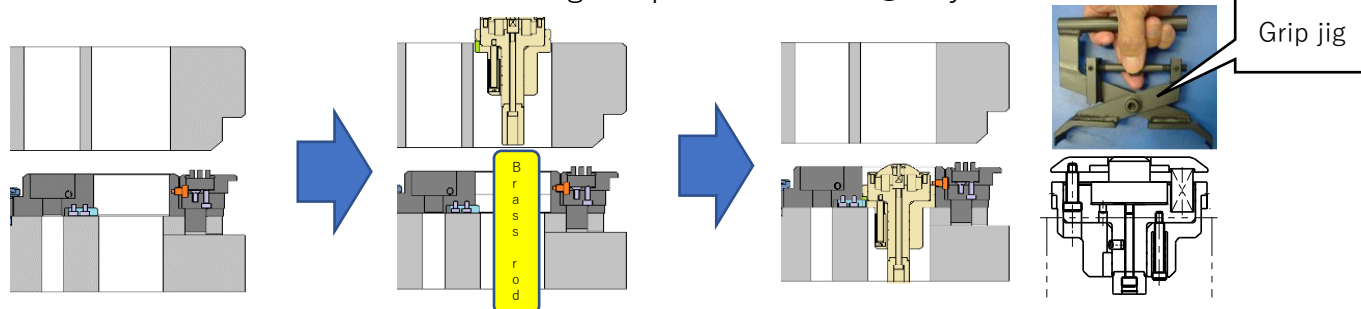
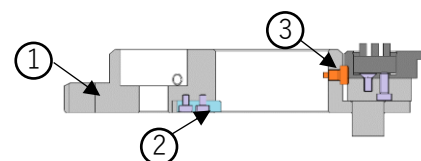

- Die holder is special to UP/DOWN.
- UP/DOWN operation must be done in outer track only.
- Put the lower part through the upper turret for mounting.
- Keep a sufficient distance between two UP/DOWN operations.
- Do not use two UP/DOWN tool next to each other.
- The length of the lower part varies among machines. For sharing a tool among several machines, the pusher may be changed. Contact us for further information.
- The UP/DOWN index indicates the size of the range that is one rank smaller than the molding size.

# Forming Tool UP/DOWN Tool Change Procedure

For UP/DOWN molding, the lower die is heavy at E station and above, so it is safer to use the lower die gripping jig shown in the photo below.

How to use

① Set the lower die on the jig

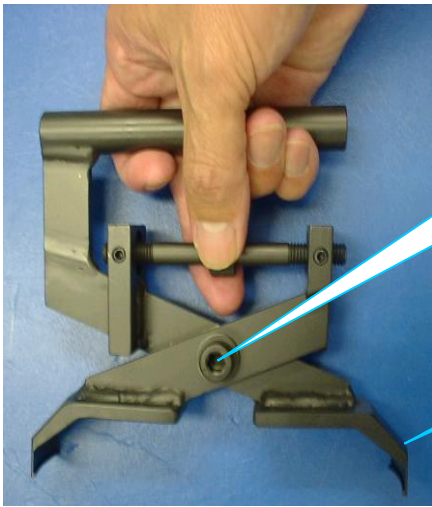

Turning the  $\phi 15$  part opens and closes the claw at the tip.

Claw

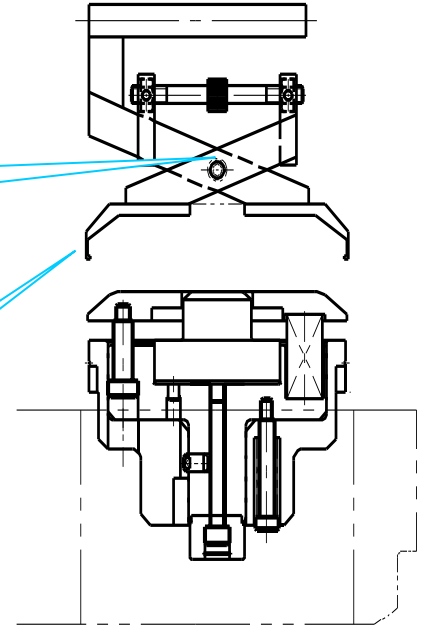

Rotating the  $\Phi 15$  section opens and closes the jaws, so adjust them so that they grip the stripper on the lower die.

※After setting it up, make sure it is fixed in place to prevent it from falling.

② Insert from the upper turret



The die is inserted from the upper turret by aligning the die keyway (on the back of the die) with the key position of the die holder.

Once the lower die is in contact with the die holder, remove the jig. (The claw open when the  $\Phi 15$  part is loosened.)

※Note: Work carefully to avoid damaging the turret.

※ When using a jig, the claw cannot be hooked unless the lower die is removed from the die holder.

Set screw

Key

Make sure that the top surface of the lower die of the UP/DOWN die is flush with the top surface of the adjacent die, then tighten the set screw.

③ Operation check

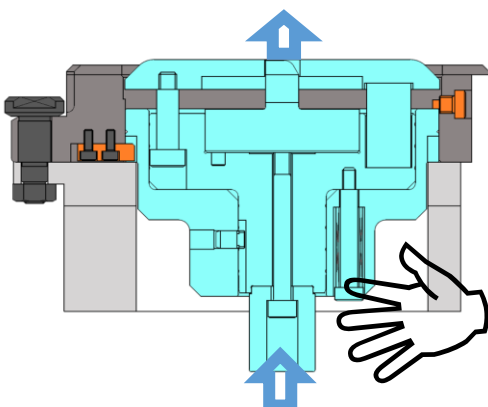

After tightening the set screw, push the pusher up by hand and check that the UP/DOWN mold moves up and down smoothly.

Removal is the reverse procedure.

# Ball Tool (BT-III)

Ball Tool (BT-III) is MTL's original deburring tool. By rolling over the jagged surface, the balls constricts the slits on the both side and makes the cut surface milder and smoother.

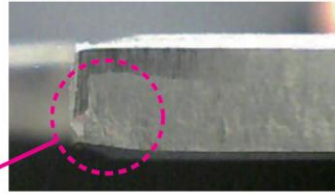
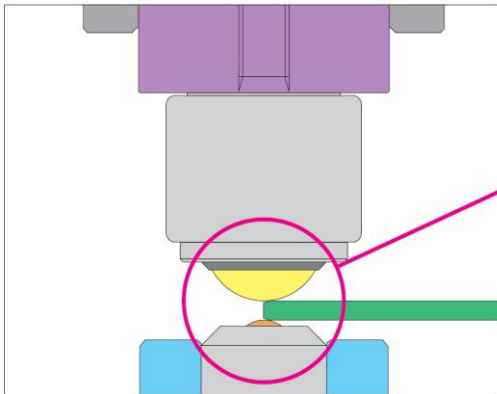

Range: B

Material/Thickness

- Mild steel : t0.8~4.5
- Stainless : t0.8~3.0
- Aluminum : t0.8~3.0

Processing range

- Minimum hole diameter :  $\phi$  2.0
  - minimum slit width : 1mm
- (When tool offset is set to 0.5 mm)

For CAMPATH

CAMPATH-G4 Ver1.08 later  
Should have the deburring tool control support option.



# Laser Edge Tool (BL- I )

A laser edge tool is a tool in which the bearings set in the upper tool (punch) and lower tool (die) trace portions processed by laser beam machining to crush the cross-sectional edges of those portions as a slight-chamfering-like treatment.

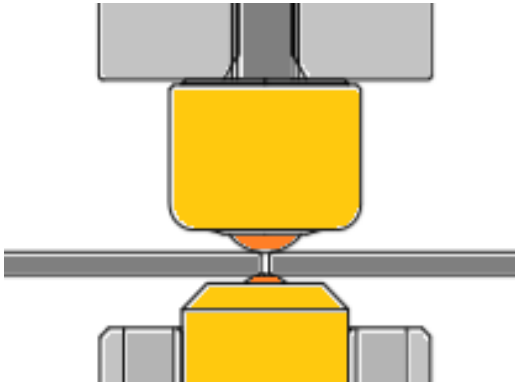

Range: B

Material/thickness

- Mild steel : t0.8~6.0
- Stainless : t0.8~3.0
- Aluminum : t0.8~3.0

Processing range

- Minimum hole diameter :  $\phi$  0.6
- Minimum slit width : 0.3

The minimum machining amount varies depending on the tool offset amount.

For CAMPATH

- CAMPATH G4Advanced Ver2.01C later
- Laser edge tool compatible software is required.

※

- Always check the cutting condition of the product and use it when there is no dross.
- This die cannot be used to remove burrs from punched areas.  
Please use the ball tool BT-III.
- Please set it on the out track and use it.  
(Placing a ball tool on the in-track station will result in a reduced distance from the adjacent station. If under this condition a thick plate is processed at a station next to the ball tool, the lower tool (die) of the ball tool may undergo failure.)
- Two or more joints to be provided.

# Style 114 Punch Holder

For upward forming, use the 114 type punch holder.

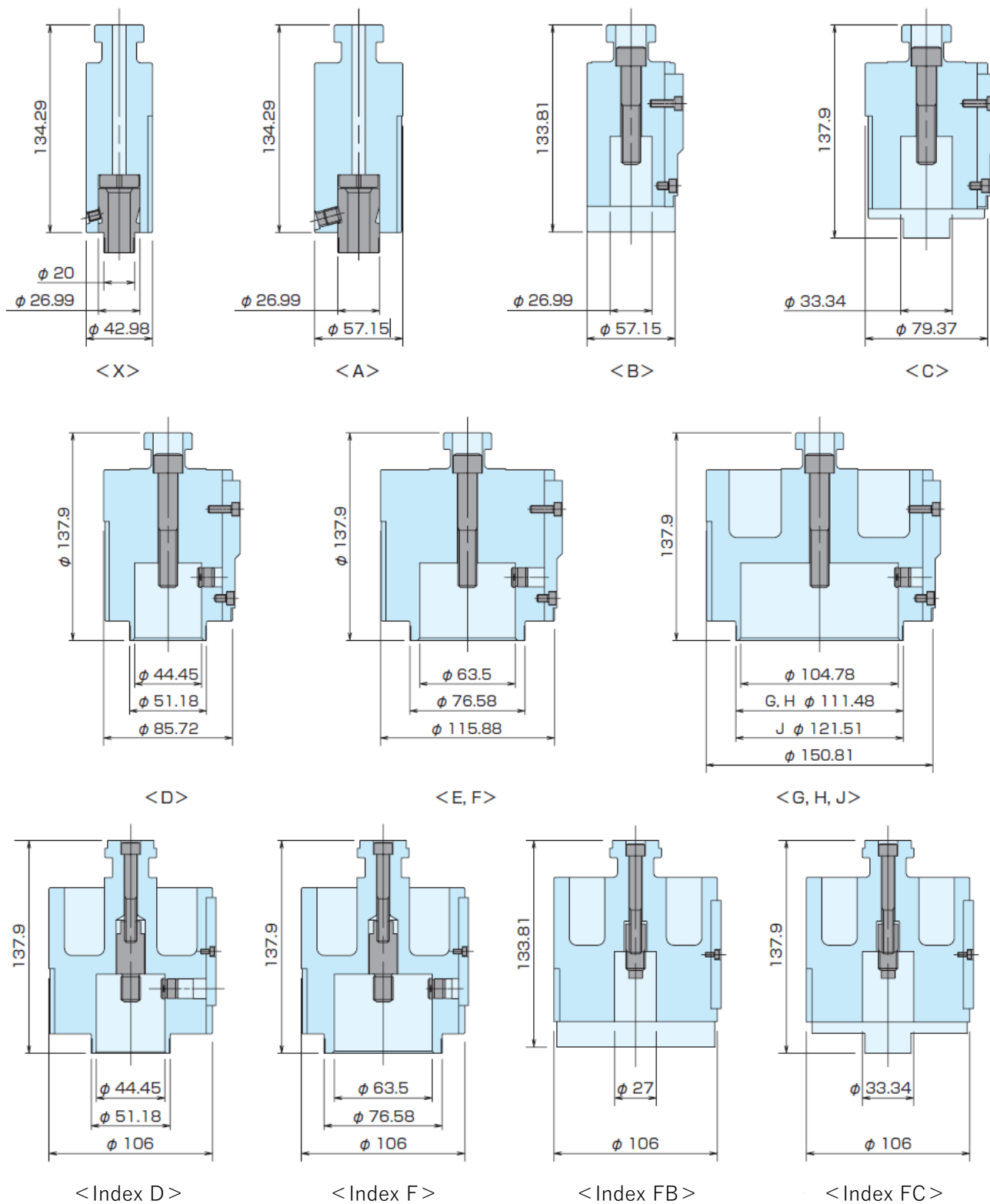

# Murata Tool/Sheet metal processing peripherals

## Tool grinder MTA-170 $\alpha$

Auto tool grinder



## Tool grinder MTA-150 $\alpha$

Manual tool grinder



## Deburring machine DB1000F · DB1000S · DB600R

Burr removal, laser sharp edge/dross removal



## Inquiry and purchase regarding tooling

**MURATA TOOL,LTD.**

【e-mail】 [mtl@syd.muratec.co.jp](mailto:mtl@syd.muratec.co.jp)

---

### **MURATA TOOL,LTD.**

881-1 Ichihasi, Kamono-cho, Minokamo-shi GIFU 505-0056 JAPAN  
TEL: +81-(0)568-65-3139 FAX: +81-(0)568-65-3466

### **MURATA MACHINERY,LTD.**

#### **MACHINE TOOLS DIVISION**

2, Nakajima, Hashizume, Inuyama-shi, Aichi, 484-8502, JAPAN  
TEL: +81-(0)568-61-3645 FAX: +81-(0)568-61-6455  
<http://www.muratec.co.jp>

- The machines shown in the catalogue include some optional items and may vary in appearance from the actual machines.
- Specifications and designs are subject to change without prior notice.